

Operating Instructions

Process pressure transmitter CPT-2x

GB

Slave for electronic differential pressure
Ceramic sensor



Process pressure transmitter CPT-2x



Contents

1	About this document	4
1.1	Function	4
1.2	Target group	4
1.3	Symbols used	4
2	For your safety	5
2.1	Authorised personnel	5
2.2	Appropriate use	5
2.3	Warning about incorrect use	5
2.4	General safety instructions	5
2.5	EU conformity	5
2.6	Installation and operation in the USA and Canada	6
3	Product description	7
3.1	Configuration	7
3.2	Principle of operation	8
3.3	Supplementary cleaning procedures	13
3.4	Packaging, transport and storage	13
4	Mounting	15
4.1	General instructions	15
4.2	Instructions for oxygen applications	17
4.3	Ventilation and pressure compensation	17
4.4	Combination Master - Slave	19
4.5	Level measurement	20
4.6	Differential pressure measurement	21
4.7	Interface measurement	22
4.8	Density measurement	23
4.9	Density-compensated level measurement	24
4.10	External housing	26
5	Connecting to power supply	27
5.1	Preparing the connection	27
5.2	Connecting	28
5.3	Single chamber housing	29
5.4	External housing with version IP68 (25 bar)	30
5.5	Connection example	32
6	Set up with the display and adjustment module	33
6.1	Parameter adjustment - Extended adjustment	33
7	Diagnosis, asset management and service	46
7.1	Maintenance	46
7.2	Cleaning - hygienic connection with compression nut	46
7.3	Rectify faults	47
7.4	Exchange process module on version IP68 (25 bar)	47
7.5	Instrument repair	48
8	Dismount	49
8.1	Dismounting steps	49
8.2	Disposal	49
9	Supplement	50

9.1	Technical data	50
9.2	Calculation of the total deviation.....	60
9.3	Practical example.....	61
9.4	Dimensions	64
9.5	Trademark	72

Safety instructions for Ex areas



Take note of the Ex specific safety instructions for Ex applications. These instructions are attached as documents to each instrument with Ex approval and are part of the operating instructions.

Editing status: 2020-05-12

1 About this document

1.1 Function

This instruction provides all the information you need for mounting, connection and setup as well as important instructions for maintenance, fault rectification, the exchange of parts and the safety of the user. Please read this information before putting the instrument into operation and keep this manual accessible in the immediate vicinity of the device.

1.2 Target group

This operating instructions manual is directed to trained personnel. The contents of this manual must be made available to the qualified personnel and implemented.

1.3 Symbols used



Information, note, tip: This symbol indicates helpful additional information and tips for successful work.



Note: This symbol indicates notes to prevent failures, malfunctions, damage to devices or plants.



Caution: Non-observance of the information marked with this symbol may result in personal injury.



Warning: Non-observance of the information marked with this symbol may result in serious or fatal personal injury.



Danger: Non-observance of the information marked with this symbol results in serious or fatal personal injury.



Ex applications

This symbol indicates special instructions for Ex applications.



List

The dot set in front indicates a list with no implied sequence.



Sequence of actions

Numbers set in front indicate successive steps in a procedure.



Battery disposal

This symbol indicates special information about the disposal of batteries and accumulators.

2 For your safety

2.1 Authorised personnel

All operations described in this documentation must be carried out only by trained, qualified personnel authorised by the plant operator. During work on and with the device, the required personal protective equipment must always be worn.

2.2 Appropriate use

CPT-2x is a slave sensor for electronic differential pressure measurement.

You can find detailed information about the area of application in chapter "*Product description*".

Operational reliability is ensured only if the instrument is properly used according to the specifications in the operating instructions manual as well as possible supplementary instructions.

2.3 Warning about incorrect use

Inappropriate or incorrect use of this product can give rise to application-specific hazards, e.g. vessel overfill through incorrect mounting or adjustment. Damage to property and persons or environmental contamination can result. Also, the protective characteristics of the instrument can be impaired.

2.4 General safety instructions

This is a state-of-the-art instrument complying with all prevailing regulations and directives. The instrument must only be operated in a technically flawless and reliable condition. The operator is responsible for the trouble-free operation of the instrument. When measuring aggressive or corrosive media that can cause a dangerous situation if the instrument malfunctions, the operator has to implement suitable measures to make sure the instrument is functioning properly.

The safety instructions in this operating instructions manual, the national installation standards as well as the valid safety regulations and accident prevention rules must be observed by the user.

For safety and warranty reasons, any invasive work on the device beyond that described in the operating instructions manual may be carried out only by personnel authorised by the manufacturer. Arbitrary conversions or modifications are explicitly forbidden. For safety reasons, only the accessory specified by the manufacturer must be used.

To avoid any danger, the safety approval markings and safety tips on the device must also be observed.

2.5 EU conformity

The device fulfils the legal requirements of the applicable EU directives. By affixing the CE marking, we confirm the conformity of the instrument with these directives.

The EU conformity declaration can be found on our homepage.

Due to the design of its process fittings, the device does not subject of EU pressure device directive if it is operated at process pressures ≤ 200 bar.

2.6 Installation and operation in the USA and Canada

This information is only valid for USA and Canada. Hence the following text is only available in the English language.

Installations in the US shall comply with the relevant requirements of the National Electrical Code (ANSI/NFPA 70).

Installations in Canada shall comply with the relevant requirements of the Canadian Electrical Code.

3 Product description

3.1 Configuration

Scope of delivery

The scope of delivery encompasses:

- Pressure transmitter CPT-2x - Slave sensor
- Ready-made connection cable, unassembled cable gland

The further scope of delivery encompasses:

- Documentation
 - Quick setup guide CPT-2x
 - Test certificate for pressure transmitters
 - Instructions for optional instrument features
 - Ex-specific "*Safety instructions*" (with Ex versions)
 - If necessary, further certificates



Information:

Optional instrument features are also described in this operating instructions manual. The respective scope of delivery results from the order specification.

Scope of this operating instructions

This operating instructions manual applies to the following instrument versions:

- Hardware from 1.0.0
- Software version from 1.0.0



Note:

You can find the hardware and software version of the instrument as follows:

- On the type plate of the electronics module
- In the adjustment menu under "*Info*"

Type label

The type label contains the most important data for identification and use of the instrument:

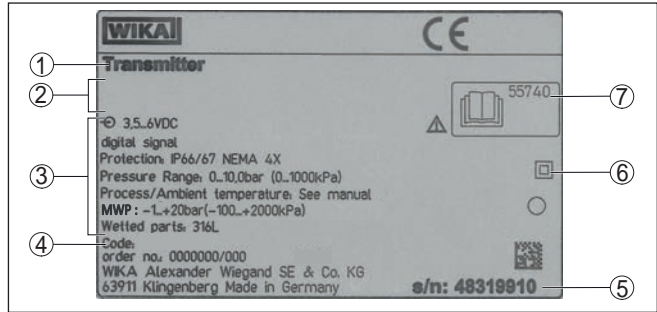

Fig. 1: Layout of the type label (example)

- 1 Instrument type
- 2 Field for approvals
- 3 Technical data
- 4 Product code
- 5 Serial number of the instrument
- 6 Symbol of the device protection class
- 7 ID numbers, instrument documentation

3.2 Principle of operation

Application area

CPT-2x is suitable for applications in virtually all industries. It is used for the measurement of the following pressure types.

- Gauge pressure
- Absolute pressure
- Vacuum

Measured products

Measured products are gases, vapours and liquids.

Depending on the process fitting and measurement setup, measured products can be also viscous or contain abrasive substances.

Measured variables

The electronic differential pressure measurement is suitable for the measurement of the following process variables:

- Level
- Flow
- Differential pressure
- Density
- Interface
- Level, density-compensated

Electronic differential pressure

The CPT-2x slave sensor is combined with a sensor from the CPT-2x series for electronic differential pressure measurement.

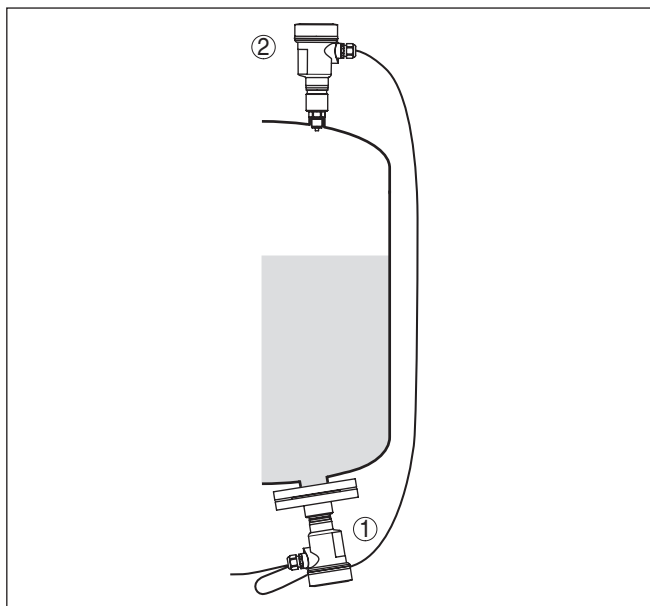

Fig. 2: Example, electronic differential pressure for level measurement in pressurized vessel

- 1 CPT-2x
- 2 CPT-2x - Slave sensor

The sensors are connected via a screened four-wire cable. The measured value from the slave sensor is read in and factored into the calculations. Power supply and parameter adjustment are carried out through the master sensor.



Information:

The sensor versions "Relative pressure climate-compensated" as well as "Double chamber housing" are not suitable for connection of a slave sensor.

You can find further information in chapter "Combination Master - Slave" of this operating instructions.

Measuring system pressure

Sensor element is the measuring cell with robust ceramic diaphragm. The process pressure deflects the ceramic diaphragm and causes a capacitance change in the measuring cell. This capacitance change is converted into an electrical signal and output as measured value via the output signal.

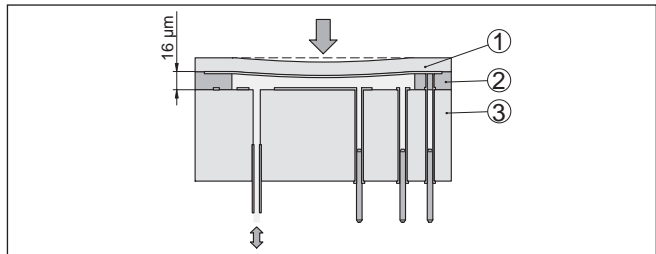

Fig. 3: Configuration of the ceramic measuring cell

- 1 Process diaphragm
- 2 Glass joint
- 3 Base element

Measuring system temperature

A temperature sensor in the ceramic diaphragm of the $\varnothing 28$ mm or on the ceramic base of the $\varnothing 17.5$ mm measuring cell detects the actual process temperature. The temperature value is output via the master sensor.

Even extreme jumps in process temperature are immediately detected by the $\varnothing 28$ mm measuring cell. The values are compared with those of an additional temperature measurement on the ceramic base body. Within a few measuring cycles, the intelligent sensor electronics compensates for otherwise unavoidable measurement deviations caused by temperature shocks in the range. Depending on the adjusted damping, these cause only slight and brief changes in the output signal.¹⁾

Pressure types

Relative pressure: the measuring cell is open to the atmosphere. The ambient pressure is detected in the measuring cell and compensated. It thus has no influence on the measured value.

Absolute pressure: the measuring cell contains vacuum and is encapsulated. The ambient pressure is not compensated and does hence influence the measured value.

Seal concepts

The following presentations show examples for the installation of the ceramic measuring cell into the process fitting and the different seal concepts.

Recessed installation

The recessed installation is particularly suitable for applications with gases, vapours and clear liquids. The measuring cell seal is positioned laterally as well as in addition in front.

¹⁾ At temperatures above 100 °C the function is automatically deactivated, at temperatures below 95 °C it is automatically reactivated.

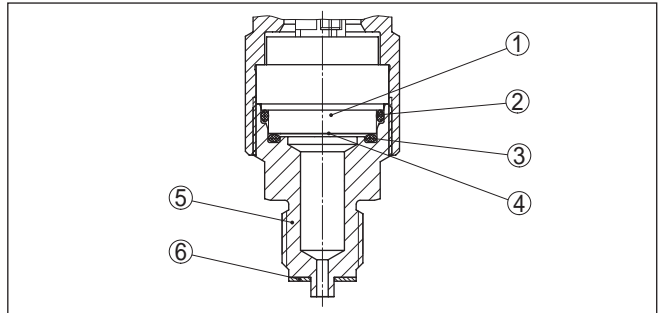

Fig. 4: Recessed installation of the measuring cell (example: manometer connection G $\frac{1}{2}$)

- 1 Measuring cell
- 2 Seal for the measuring cell
- 3 Additional, front seal for measuring cell
- 4 Diaphragm
- 5 Process fitting
- 6 Seal for the process fitting

Front-flush mounting with single seal

The front-flush installation is particularly suitable for applications with viscous and abrasive media and in case of buildup. The measuring cell seal is positioned laterally.

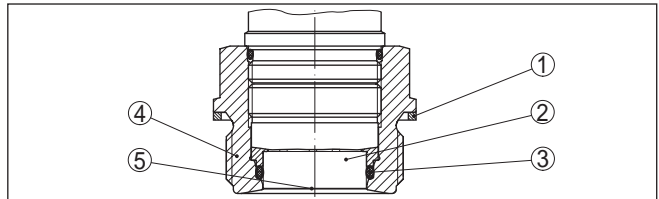

Fig. 5: Front-flush installation of the measuring cell (example: thread G1 $\frac{1}{2}$)

- 1 Seal for the process fitting
- 2 Measuring cell
- 3 Seal for the measuring cell
- 4 Process fitting
- 5 Diaphragm

Completely front-flush mounting with single seal

The completely front-flush mounting is particularly suitable for applications in the paper industry. The diaphragm is in the pulp flow, is hence cleaned and protected against buildup.

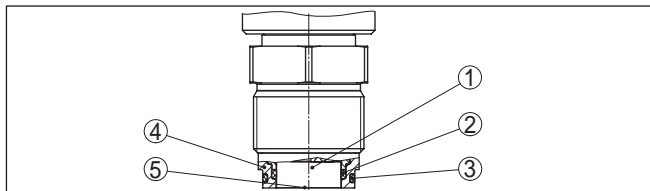

Fig. 6: Front-flush installation of the measuring cell (example: M30 x 1.5)

- 1 Measuring cell
- 2 Seal for the measuring cell
- 3 Seal for the process fitting
- 4 Process fitting
- 5 Diaphragm

Front-flush mounting with double seal

The front-flush installation is particularly suitable for applications with viscous media. The additional, front sealing protects the glass joint of the measuring cell against chemical attack and the measuring cell electronics against diffusion of aggressive gases from the process.

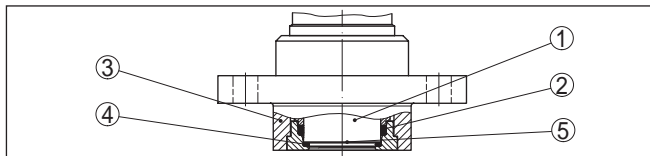

Fig. 7: Front-flush installation of the measuring cell with double seal (example: flange connection with extension)

- 1 Measuring cell
- 2 Seal for the measuring cell
- 3 Process fitting
- 4 Additional, front seal for measuring cell
- 5 Diaphragm

Installation in hygienic fitting

The front-flush, hygienic installation of the measuring cell is particularly suitable for food applications. The sealings are installed gap-free. The form seal of the measuring cell protects also the glass joint.

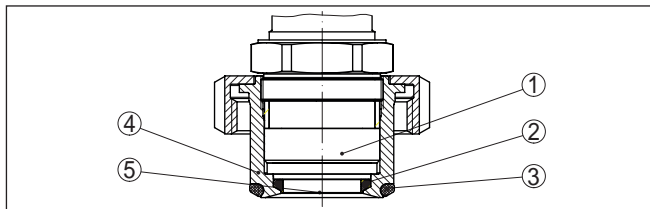

Fig. 8: Hygienic installation of the measuring cell (example: hygienic fitting with compression nut)

- 1 Measuring cell
- 2 Form seal for the measuring cell
- 3 Gap-free seal for process fitting
- 4 Process fitting
- 5 Diaphragm

Installation in hygienic fitting acc. to 3-A

The front-flush, hygienic installation of the measuring cell acc. to 3A is particularly suitable for food applications. The sealings are installed gap-free. The additional front sealing for the measuring cell protects also the glass joint. A hole in the process fitting is used for leakage detection.

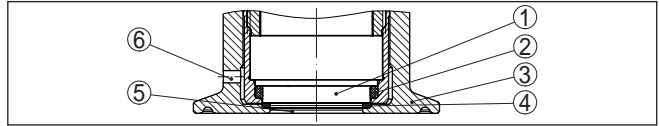

Fig. 9: Hygienic installation of the measuring cell acc. to 3-A (example: Clamp connection)

- 1 Measuring cell
- 2 Seal for the measuring cell
- 3 Process fitting
- 4 Additional, front seal for measuring cell
- 5 Diaphragm
- 5 Hole for leakage detection

3.3 Supplementary cleaning procedures

The CPT-2x is also available in the version "Oil, grease and silicone-free". These instruments have passed through a special cleaning procedure to remove oil, grease and paint-wetting impairment substances (PWIS).

The cleaning is carried out on all wetted parts as well as on surfaces accessible from outside. To keep the purity level, the instruments are immediately packed in plastic foil after the cleaning process. The purity level remains as long as the instrument is kept in the closed original packaging.



Caution:

The CPT-2x in this version may not be used in oxygen applications. For this purpose, instruments are available in the special version "Oil, grease and silicone-free for oxygen applications".

3.4 Packaging, transport and storage

Packaging

Your instrument was protected by packaging during transport. Its capacity to handle normal loads during transport is assured by a test based on ISO 4180.

The packaging consists of environment-friendly, recyclable cardboard. For special versions, PE foam or PE foil is also used. Dispose of the packaging material via specialised recycling companies.

Transport

Transport must be carried out in due consideration of the notes on the transport packaging. Nonobservance of these instructions can cause damage to the device.

Transport inspection

The delivery must be checked for completeness and possible transit damage immediately at receipt. Ascertained transit damage or concealed defects must be appropriately dealt with.

Storage

Up to the time of installation, the packages must be left closed and stored according to the orientation and storage markings on the outside.

Unless otherwise indicated, the packages must be stored only under the following conditions:

- Not in the open
- Dry and dust free
- Not exposed to corrosive media
- Protected against solar radiation
- Avoiding mechanical shock and vibration

Storage and transport temperature

- Storage and transport temperature see chapter "*Supplement - Technical data - Ambient conditions*"
- Relative humidity 20 ... 85 %

Lifting and carrying

With instrument weights of more than 18 kg (39.68 lbs) suitable and approved equipment must be used for lifting and carrying.

4 Mounting

4.1 General instructions

Process conditions



Note:

For safety reasons, the instrument must only be operated within the permissible process conditions. You can find detailed information on the process conditions in chapter "*Technical data*" of the operating instructions or on the type label.

Hence make sure before mounting that all parts of the instrument exposed to the process are suitable for the existing process conditions.

These are mainly:

- Active measuring component
- Process fitting
- Process seal

Process conditions in particular are:

- Process pressure
- Process temperature
- Chemical properties of the medium
- Abrasion and mechanical influences

Protection against moisture

Protect your instrument against moisture ingress through the following measures:

- Use a suitable connection cable (see chapter "*Connecting to power supply*")
- Tighten the cable gland or plug connector
- Lead the connection cable downward in front of the cable entry or plug connector

This applies mainly to outdoor installations, in areas where high humidity is expected (e.g. through cleaning processes) and on cooled or heated vessels.



Note:

Make sure that the degree of contamination specified in chapter "*Technical data*" meets the existing ambient conditions.



Note:

Make sure that during installation or maintenance no moisture or dirt can get inside the instrument.

To maintain the housing protection, make sure that the housing lid is closed during operation and locked, if necessary.

Screwing in

Devices with threaded fitting are screwed into the process fitting with a suitable wrench via the hexagon.

See chapter "*Dimensions*" for wrench size.

**Warning:**

The housing or the electrical connection may not be used for screwing in! Depending on the device version, tightening can cause damage, e. g. to the rotation mechanism of the housing.

Vibrations

If there is strong vibration at the mounting location, the instrument version with external housing should be used. See chapter "*External housing*".

Permissible process pressure (MWP) - Device

The permissible process pressure range is specified by "MWP" (Maximum Working Pressure) on the type label, see chapter "*Structure*". The MWP takes the element of the measuring cell and processing fitting combination with the weakest pressure into consideration and may applied permanently. The specification refers to a reference temperature of +20 °C (+68 °F). It also applies when a measuring cell with a higher measuring range than the permissible pressure range of the process fitting is installed order-related.

In order to prevent damage to the device, a test pressure may only exceed the specified MWP briefly by 1.5 times at reference temperature. The pressure stage of the process fitting as well as the overload resistance of the measuring cell are taken into consideration here (see chapter "*Technical Data*").

In addition, a temperature derating of the process fitting, e. g. with flanges, can limit the permissible process pressure range according to the respective standard.

Permissible process pressure (MWP) - Mounting accessory

The permissible process pressure range is stated on the type label. The instrument should only be operated with these pressures if the mounting accessory used also fulfils these values. This should be ensured by suitable flanges, welded sockets, tension rings with Clamp connections, sealings, etc.

Temperature limits

Higher process temperatures often mean also higher ambient temperatures. Make sure that the upper temperature limits stated in chapter "*Technical data*" for the environment of the electronics housing and connection cable are not exceeded.

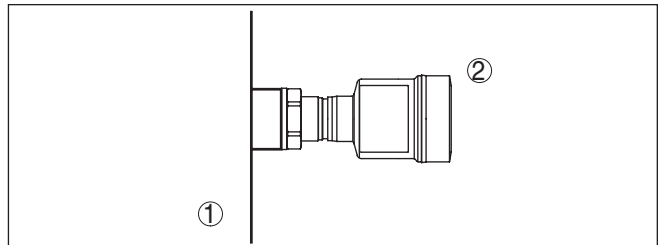

Fig. 10: Temperature ranges

- 1 Process temperature
- 2 Ambient temperature

Oxygen applications

4.2 Instructions for oxygen applications

Oxygen and other gases can be explosive when brought into contact with oils, grease and plastics, so the following measures must also be taken:

- All components of the system, e.g. measuring instruments, must be cleaned in accordance with the requirements of recognized regulations or standards
- Depending on the seal material, certain temperatures and pressures must not be exceeded in oxygen applications, see chapter "Technical data"



Danger:

Instruments for oxygen applications must be unpacked just before mounting. After removing the protective cover of the process fitting, the label "O₂" will be visible on the process fitting. Penetration of oil, grease and dirt should be avoided. Danger of explosion!

Filter element - Function

4.3 Ventilation and pressure compensation

The filter element in the electronics housing has the following functions:

- Ventilation of the electronics housing
- Atmospheric pressure compensation (with relative pressure measuring ranges)



Caution:

The filter element causes a time-delayed pressure compensation. When quickly opening/closing the housing cover, the measured value can change for approx. 5 s by up to 15 mbar.

For an effective ventilation, the filter element must be always free from buildup. In case of horizontal mounting, turn the housing so that the filter element points downward after the instrument is installed. This provides better protection against buildup.



Caution:

Do not use a high-pressure cleaner. The filter element could be damaged, which would allow moisture into the housing.

The following paragraphs describe how the filter element is arranged in the different instrument versions.

Filter element - Position

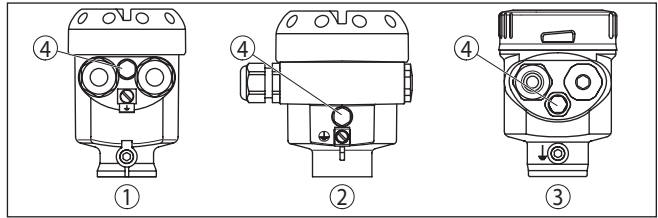

Fig. 11: Position of the filter element - non-Ex, Ex-ia version

- 1 Plastic, stainless steel housing (precision casting)
- 2 Aluminium housing
- 3 Stainless steel housing (electropolished)
- 4 Filter element

With the following instruments a blind plug is installed instead of the filter element:

- Instruments in protection IP66/IP68 (1 bar) - ventilation via capillaries in non-detachable cable
- Instruments with absolute pressure

Filter element - Position Ex-d version

→ Turn the metal ring in such a way that the filter element points downward after installation of the instrument. This provides better protection against buildup.

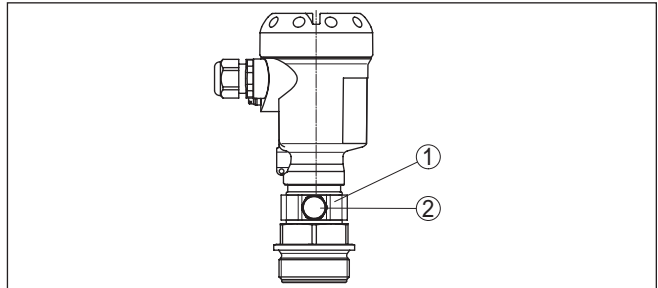

Fig. 12: Position of the filter element - Ex-d version

- 1 Rotatable metal ring
- 2 Filter element

Instruments with absolute pressure have a blind plug mounted instead of the filter element.

Instruments with Second Line of Defense

The process assembly of instruments with Second Line of Defense (gastight leadthrough) is completely encapsulated. An absolute pressure measuring cell is used so that no ventilation is required.

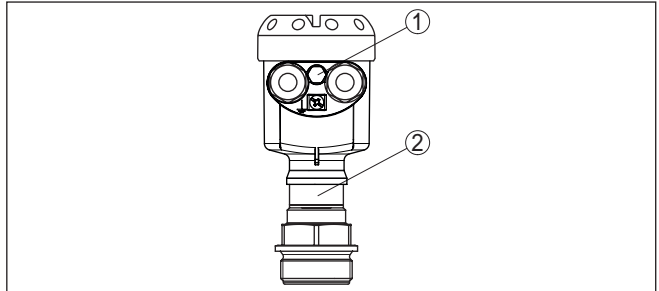

Fig. 13: Position of the filter element - gastight leadthrough

1 Filter element

Filter element - Position IP69K version

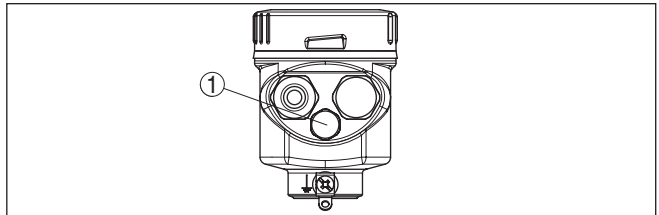

Fig. 14: Position of the filter element - IP69K version

1 Filter element

Instruments with absolute pressure have a blind plug mounted instead of the filter element.

4.4 Combination Master - Slave

In principle, any sensor combination within the instrument series is allowed. The following requirements must be fulfilled:

- Configuration, Master sensor suitable for electronic differential pressure
- Pressure type is identical for both sensors, i.e. relative pressure/relative pressure or absolute pressure/absolute pressure
- Master sensor measures the higher pressure
- Measurement setup as shown in the following chapters

The measuring range of each sensor is selected such that it fits the measuring loop. For this, the max. recommended turn down must be noted. See chapter "Technical data". It is absolutely necessary the measuring ranges of Master and Slave correspond.

Measurement result = Measured value of Master (total pressure) - measured value of Slave (static pressure)

Depending on the application, individual combinations can result, see following examples:

Example - large vessel

Data

Application: Level measurement

Medium: Water

Vessel height: 12 m, hydrostatic pressure = $12 \text{ m} \times 1000 \text{ kg/m}^3 \times 9.81 \text{ m/s}^2 = 117.7 \text{ kPa} = 1.18 \text{ bar}$

Superimposed pressure: 1 bar

Total pressure: $1.18 \text{ bar} + 1 \text{ bar} = 2.18 \text{ bar}$

Instrument selection

Nominal measuring range Master: 2.5 bar

Nominal measuring range Slave: 1 bar

Turn Down: $2.5 \text{ bar} / 1.18 \text{ bar} = 2.1 : 1$

Example - small vessel

Data

Application: Level measurement

Medium: Water

Vessel height: 500 mm, hydrostatic pressure = $0.50 \text{ m} \times 1000 \text{ kg/m}^3 \times 9.81 \text{ m/s}^2 = 4.9 \text{ kPa} = 0.049 \text{ bar}$

Superimposed pressure: 350 mbar = 0.35 bar

Total pressure: $0.049 \text{ bar} + 0.35 \text{ bar} = 0.399 \text{ bar}$

Instrument selection

Nominal measuring range Master: 0.4 bar

Nominal measuring range Slave: 0.4 bar

Turn Down: $0.4 \text{ bar} / 0.049 \text{ bar} = 8.2 : 1$

Example - orifice in pipeline

Data

Application: Differential pressure measurement

Medium: Gas

Static pressure: 0.8 bar

Differential pressure on orifice: 50 mbar = 0.050 bar

Total pressure: $0.8 \text{ bar} + 0.05 \text{ bar} = 0.85 \text{ bar}$

Instrument selection

Nominal measuring range Master: 1 bar

Nominal measuring range Slave: 1 bar

Turn Down: $1 \text{ bar} / 0.050 \text{ bar} = 20 : 1$

Output measured values

The measuring result (level, pressure difference) as well as measured value Slave (static or superimposed pressure) are output by the sensor. Depending on the instrument version, output as 4 ... 20 mA signal or digitally via HART, Profibus PA or Foundation Fieldbus.

4.5 Level measurement

Measurement setup

The master/slave combination is suitable for level measurement in a pressurized vessel

Keep the following in mind when setting up the measuring system:

- Mount the master sensor below the min. level
- Do not mount the master sensor close to the filling stream or emptying area

- Mount the master sensor so that it is protected against pressure shocks from the stirrer
- Mount the slave sensor above the max. level

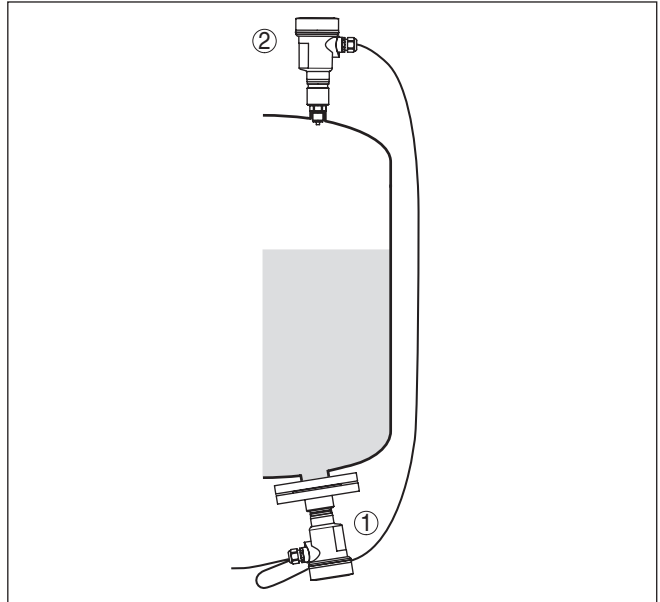

Fig. 15: Measurement setup, level measurement in pressurized vessel

- 1 CPT-2x
- 2 CPT-2x, slave sensor

Measurement setup

4.6 Differential pressure measurement

The master/slave combination is suitable for differential pressure measurement

Take note of the following instructions for the measurement setup, for example in gases:

- Mount the instruments above the measuring point

Possible condensation can then drain off into the process line.

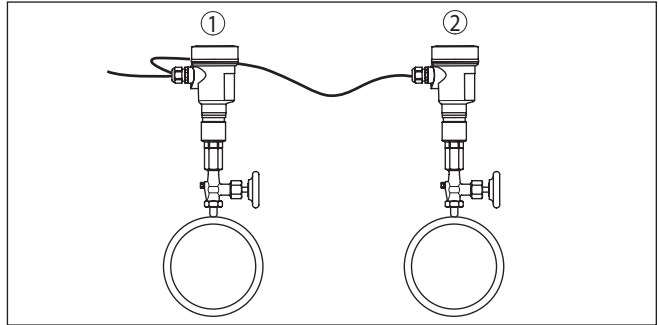

Fig. 16: Measurement setup for differential pressure measurement of gases in pipelines

- 1 CPT-2x
- 2 CPT-2x, slave sensor

Measurement setup

4.7 Interface measurement

The master/slave combination is suitable for interface measurement. Requirements for a functioning measurement are:

- Vessel with changing level
- Products with steady density
- Interface always between the measurement points
- Total level always above the upper measurement point

The mounting distance h of the two sensors should be at least 10 %, better 20 %, of the final value of the sensor measuring range. A bigger distance increases the accuracy of the interface measurement.

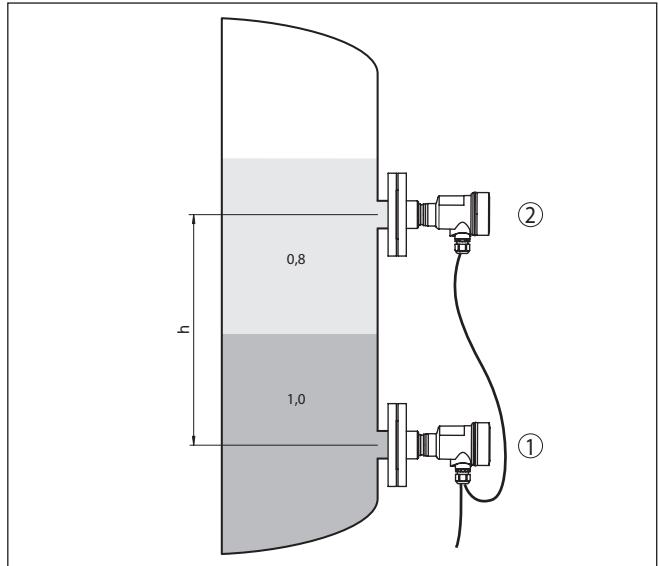

Fig. 17: Measurement setup with interface measurement, h = distance between the two measuring points

- 1 CPT-2x
- 2 CPT-2x, slave sensor

The interface measurement is possible in open as well as in closed vessels.

4.8 Density measurement

Measurement setup

The master/slave combination is suitable for density measurement. Requirements for a functioning measurement are:

- Vessel with changing level
- Distance between the measurement points as large as possible
- Level always above the upper measuring point

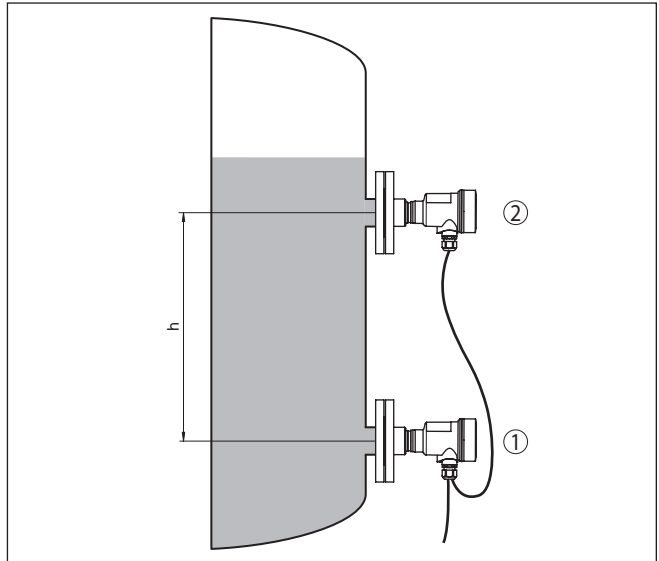

Fig. 18: Measurement setup for density measurement, h = distance between the two measuring points

- 1 CPT-2x
2 CPT-2x, slave sensor

The mounting distance h of the two sensors should be at least 10 %, better 20 %, of the final value of the sensor measuring range. A bigger distance increases the accuracy of the density measurement.

Slight density changes cause only slight changes of the measured differential pressure. The measuring range must hence be selected accordingly.

The density measurement is possible in open as well as in closed vessels.

4.9 Density-compensated level measurement

The master/slave combination is suitable for density-compensated level measurement

Keep the following in mind when setting up the measuring system:

- Mount the master sensor below the min. level
- Mount the slave sensor above the master sensor
- Mount both sensors away from the filling stream and emptying and protected against pressure shocks from the stirrer

Measurement setup

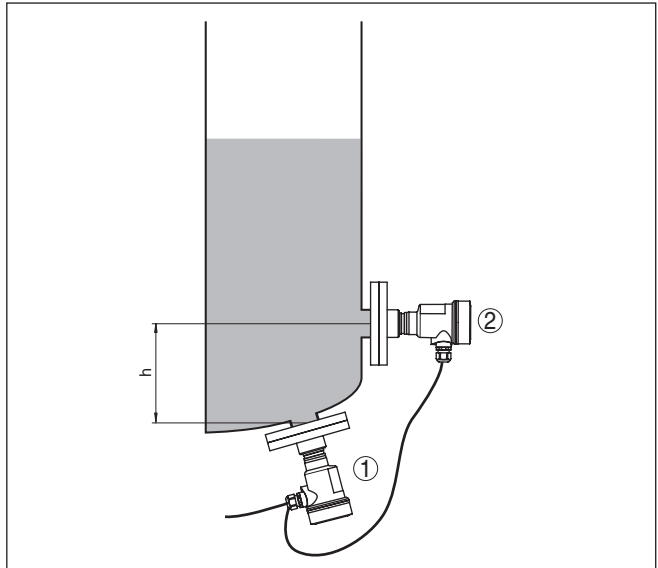

Fig. 19: Measurement setup for density-compensated level measurement, h = distance between the two measuring points

- 1 CPT-2x
- 2 CPT-2x, slave sensor

The mounting distance h of the two sensors should be at least 10 %, better 20 %, of the final value of the sensor measuring range. A bigger distance increases the accuracy of the density compensation.

The density-compensated level measurement starts with the stored density 1 kg/dm^3 . As soon as both sensors are covered, this value will be replaced by the calculated density. Density compensation means that the level value in height units and the adjustment values do not change in case of a fluctuating density.

The density-compensated level measurement is only possible in open, i.e. unpressurized vessels.

4.10 External housing

Configuration

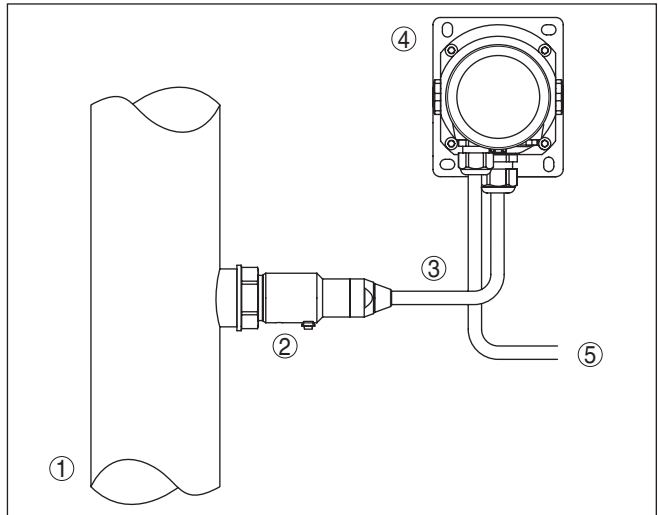

Fig. 20: Configuration, process module, external housing

- 1 Pipeline
- 2 Process module
- 3 Connection cable process assembly - External housing
- 4 External housing
- 5 Signal cable

5 Connecting to power supply

5.1 Preparing the connection

Safety instructions

Always keep in mind the following safety instructions:

- Carry out electrical connection by trained, qualified personnel authorised by the plant operator
- If overvoltage surges are expected, overvoltage arresters should be installed



Warning:

Only connect or disconnect in de-energized state.

Voltage supply

The voltage supply and the signal transmission are carried out via the four-wire, screened connection cable from the master sensor.

You can find the data for this signal circuit in chapter "*Technical data*".

Connection cable

The instrument is connected via the supplied four-wire, screened cable. This cable is absolutely necessary for reliable functioning of the electronic differential measurement.

Use a cable gland suitable for the cable diameter to ensure the seal effect of the cable gland (IP protection).

Cable screening and grounding

The shielding of the cable between master and slave sensor must be connected on both ends to ground potential. In the sensor, the shielding is connected directly to the internal ground terminal. The ground terminal on the outside of the housing must be connected to the ground potential (low impedance).

Cable glands

Metric threads

In the case of instrument housings with metric thread, the cable glands are screwed in at the factory. They are sealed with plastic plugs as transport protection.



Note:

You have to remove these plugs before electrical connection.

NPT thread

In the case of instrument housings with self-sealing NPT threads, it is not possible to have the cable entries screwed in at the factory. The free openings for the cable glands are therefore covered with red dust protection caps as transport protection.



Note:

Prior to setup you have to replace these protective caps with approved cable glands or close the openings with suitable blind plugs.

On plastic housings, the NPT cable gland or the Conduit steel tube must be screwed into the threaded insert without grease.

Max. torque for all housings, see chapter "*Technical data*".

5.2 Connecting

Connection technology

The connection to the Master sensor is carried out through spring-loaded terminals in the respective housing. For this, use the supplied, confectioned cable. Solid cores as well as flexible cores with cable end sleeves are inserted directly into the terminal openings.

In case of flexible cores without end sleeves, press the terminal from above with a small screwdriver, the terminal opening is then free. When the screwdriver is released, the terminal closes again.



Information:

The terminal block is pluggable and can be removed from the electronics. To do this, lift the terminal block with a small screwdriver and pull it out. When reinserting the terminal block, you should hear it snap in.

You can find further information on the max. wire cross-section under "*Technical data - Electromechanical data*".

Connection procedure

Proceed as follows:

1. Unscrew the housing lid
2. Loosen compression nut of the cable gland and remove blind plug
3. Remove approx. 10 cm (4 in) of the cable mantle, strip approx. 1 cm (0.4 in) insulation from the individual wires or use supplied connection cable
4. Insert the cable into the sensor through the cable entry



Fig. 21: Connection steps 5 and 6

5. Insert the wire ends into the terminals according to the wiring plan
6. Check the hold of the wires in the terminals by lightly pulling on them
7. Connect the shielding to the internal ground terminal, connect the external ground terminal to potential equalisation

8. Tighten the compression nut of the cable entry gland. The seal ring must completely encircle the cable
9. Unscrew the blind plug on the Master, screw in the supplied cable gland
10. Connection cable to Master, see steps 3 to 8
11. Screw the housing lid back on

The electrical connection is finished.

5.3 Single chamber housing



The following illustration applies to the non-Ex, Ex-ia and Ex-d-ia version.

Electronics and connection compartment

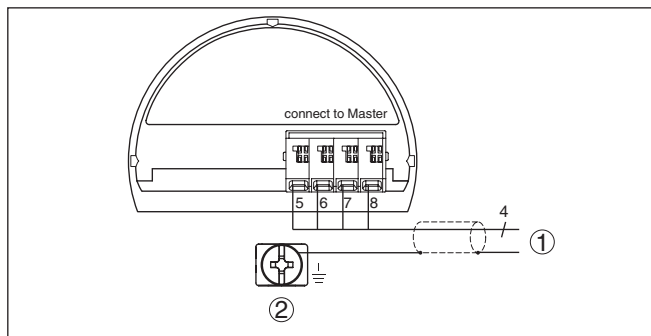

Fig. 22: Wiring plan CPT-2x Slave sensor

- 1 To the Master sensor
- 2 Ground terminal for connection of the cable screening²⁾

²⁾ Connect shielding here. Connect ground terminal on the outside of the housing to ground as prescribed. The two terminals are galvanically connected.

5.4 External housing with version IP68 (25 bar)

Overview

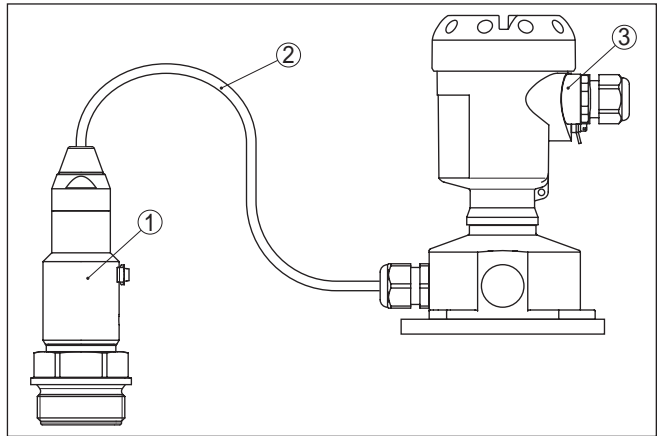

Fig. 23: CPT-2x in IP68 version 25 bar with axial cable outlet, external housing

- 1 Transmitter
- 2 Connection cable
- 3 External housing

Electronics and connection compartment for power supply

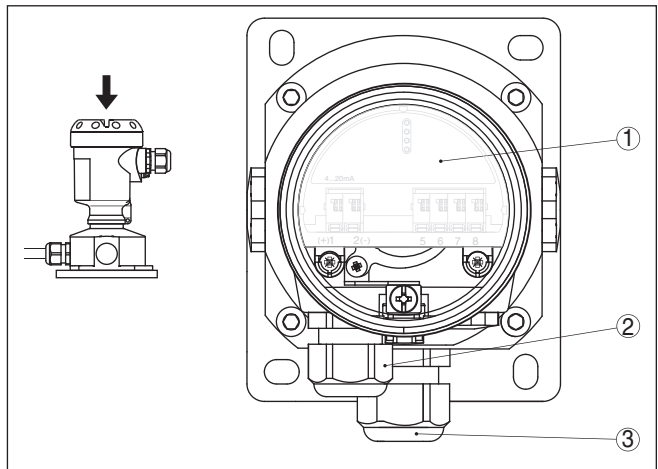

Fig. 24: Electronics and connection compartment

- 1 Electronics module
- 2 Cable gland for voltage supply
- 3 Cable gland for connection cable, transmitter

Terminal compartment, housing socket

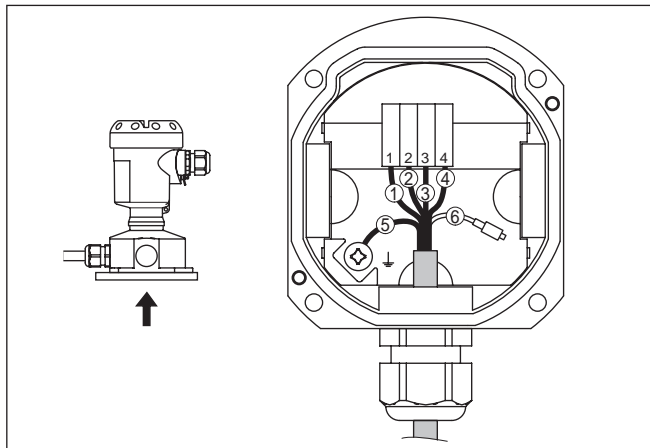

Fig. 25: Connection of the process component in the housing base

- 1 Yellow
- 2 White
- 3 Red
- 4 Black
- 5 Shielding
- 6 Breather capillaries

Electronics and connection compartment

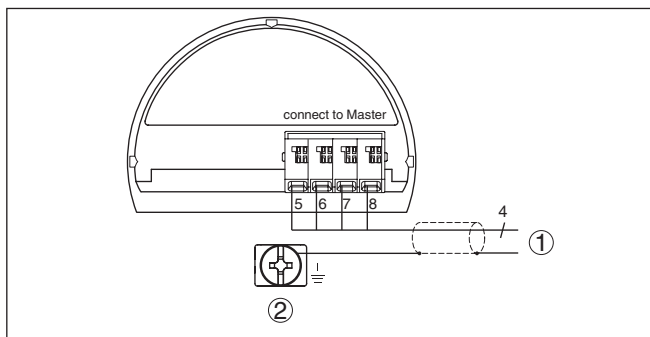

Fig. 26: Wiring plan CPT-2x Slave sensor

- 1 To the Master sensor
- 2 Ground terminal for connection of the cable screening³⁾

³⁾ Connect shielding here. Connect ground terminal on the outside of the housing to ground as prescribed. The two terminals are galvanically connected.

**Connection example,
electronic differential
pressure**

5.5 Connection example

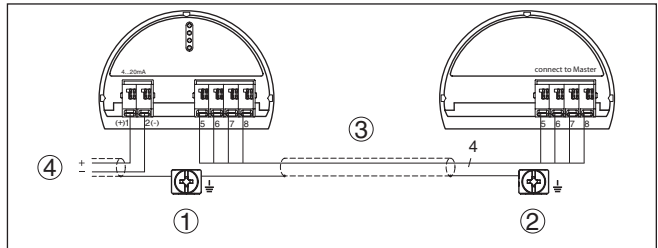

Fig. 27: Connection example, electronic differential pressure

- 1 Master sensor
- 2 Slave sensor
- 3 Connection cable
- 4 Supply and signal circuit, Master sensor

Connection between master and sensor is carried out according to the table:

Master sensor	Slave sensor
Terminal 5	Terminal 5
Terminal 6	Terminal 6
Terminal 7	Terminal 7
Terminal 8	Terminal 8

6 Set up with the display and adjustment module

6.1 Parameter adjustment - Extended adjustment

For technically demanding measuring points, you can carry out extended settings in "*Extended adjustment*".

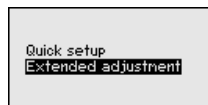

Main menu

The main menu is divided into five sections with the following functions:

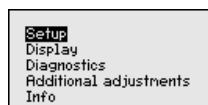

Setup: Settings, e.g., for measurement loop name, application, units, position correction, adjustment, signal output

Display: Settings, e.g., for language, measured value display, lighting

Diagnosis: Information, e.g. on instrument status, pointer, measurement reliability, simulation

Additional adjustments: PIN, date/time, reset, copy function

Info: Instrument name, hardware and software version, date of manufacture, sensor features

In the main menu item "*Setup*", the individual submenu items should be selected one after the other and provided with the correct parameter values.

The following submenu points are available:

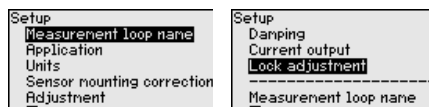

In the following section, the menu items from the menu "*Setup*" for electronic differential pressure measurement are described in detail. Depending on the selected application, different sections are relevant.



Information:

Further menu items of the menu "*Setup*" as well as the complete menus "*Display*", "*Diagnosis*", "*Additional adjustments*" and "*Info*" are described in the operating instructions of the respective master sensor.

6.1.1 Setup

Application

In this menu item you activate/deactivate the slave sensor for electronic differential pressure and select the application.

The CPT-2x in conjunction with a slave sensor can be used for flow, differential pressure, density and interface measurement. The default setting is differential pressure measurement. Switchover is carried out in the adjustment menu.

If you have connected a slave sensor, you confirm this with "Activate".



Note:

It is absolutely necessary to activate the slave sensor to have the applications displayed in the electronic differential pressure measurement menus.



Enter the requested parameters via the appropriate keys, save your settings with **[OK]** and jump to the next menu item with the **[ESC]** and the **[->]** key.

Units

In this menu item, you determine the units for the "Min. adjustment/Zero" and "Max. adjustment/Span" as well as the static pressure.

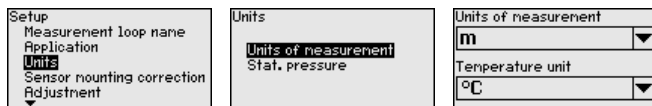

If the level should be adjusted in a height unit, the density of the medium must also be entered later during the adjustment.

In addition, the unit is determined in the menu item "Peak value temperature".

Enter the requested parameters via the appropriate keys, save your settings with **[OK]** and jump to the next menu item with the **[ESC]** and the **[->]** key.

Position correction

Especially with chemical seal systems, the installation position of the instrument can shift (offset) the measured value. Position correction compensates this offset. In the process, the actual measured value is taken over automatically. With relative pressure measuring cells a manual offset can also be carried out.

There are the following possibilities for a position correction with a master/slave combination

- Automatic correction for both sensors
- Manual correction for the Master (differential pressure)
- Manual correction for the Slave (static pressure)

With a master/slave combination in the application "*Density-compensated level measurement*" there are the following additional options for the position correction

- Automatic correction, master (level)
- Manual correction for the Master (level)

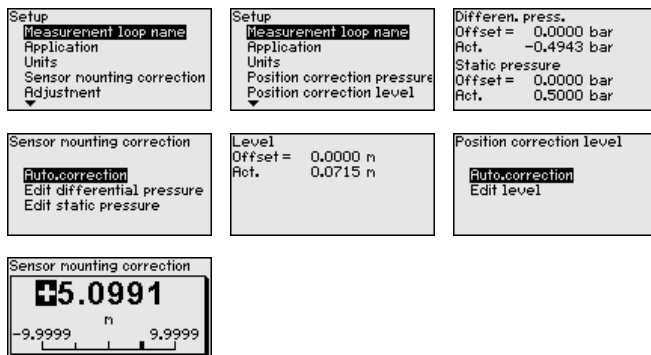

During an automatic position correction, the current measured value is accepted as the correction value. This value must not be influenced/corrupted by product coverage or static pressure.

In case of a manual position correction, the offset value is determined by the user. Select for this purpose the function "*Edit*" and enter the requested value.

Save your settings with **[OK]** and move with **[ESC]** and **[>]** to the next menu item.

After the position correction is carried out, the actual measured value is corrected to 0. The corrective value appears with an inverse sign as offset value in the display.

The position correction can be repeated any number of times.

Adjustment

CPT-2x always measures pressure independently of the process variable selected in the menu item "*Application*". To output the selected process variable correctly, an allocation of the output signal to 0 % and 100 % must be carried out (adjustment).

With the application "*Level*", the hydrostatic pressure, e.g. with full and empty vessel, is entered for adjustment. A superimposed pressure is detected by the slave sensor and automatically compensated. See the following example:

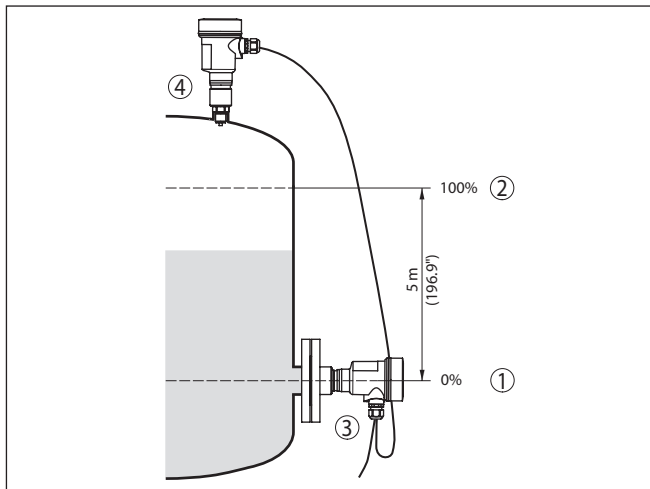

Fig. 28: Parameter adjustment example "Min./max. adjustment, level measurement"

- 1 Min. level = 0 % corresponds to 0.0 mbar
- 2 Max. level = 100 % corresponds to 490.5 mbar
- 3 CPT-2x
- 4 CPT-2x, slave sensor

If these values are not known, an adjustment with filling levels of e.g. 10 % and 90 % is also possible. By means of these settings, the real filling height is then calculated.

The actual product level during this adjustment is not important, because the min./max. adjustment is always carried out without changing the product level. These settings can be made ahead of time without the instrument having to be installed.



Note:

If the adjustment ranges are exceeded, the entered value will not be accepted. Editing can be interrupted with **[ESC]** or corrected to a value within the adjustment ranges.

For the other process variables such as e.g. process pressure, differential pressure or flow, the adjustment is performed in like manner.

Min. adjustment level

Proceed as follows:

1. Select the menu item "Setup" with **[->]** and confirm with **[OK]**. Now select with **[->]** the menu item "Adjustment", then "Min. adjustment" and confirm with **[OK]**.



2. Edit the percentage value with **[OK]** and set the cursor to the requested position with **[->]**.

3. Set the requested percentage value (e.g. 10 %) with **[+]** and save with **[OK]**. The cursor jumps now to the pressure value.
4. Enter the pressure value corresponding to the min. level (e.g. 0 mbar).
5. Save settings with **[OK]** and move with **[ESC]** and **[->]** to the max. adjustment.

The min. adjustment is finished.

For an adjustment with filling, simply enter the actual measured value indicated at the bottom of the display.

Max. adjustment level

Proceed as follows:

1. Select with **[->]** the menu item Max. adjustment and confirm with **[OK]**.

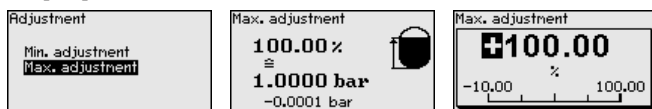

2. Edit the percentage value with **[OK]** and set the cursor to the requested position with **[->]**.
3. Set the requested percentage value (e.g. 90 %) with **[+]** and save with **[OK]**. The cursor jumps now to the pressure value.
4. Enter the pressure value for the full vessel (e.g. 900 mbar) corresponding to the percentage value.
5. Save settings with **[OK]**

The max. adjustment is finished.

For an adjustment with filling, simply enter the actual measured value indicated at the bottom of the display.

Min. adjustment flow

Proceed as follows:

1. Select the menu item "Setup" with **[->]** and confirm with **[OK]**.
Now select with **[->]** the menu item "Min. adjustment" and confirm with **[OK]**.

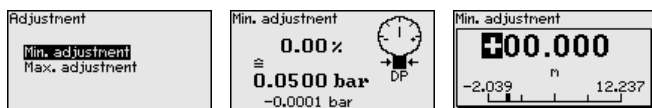

2. Edit the mbar value with **[OK]** and set the cursor to the requested position with **[->]**.
3. Set the requested mbar value with **[+]** and store with **[OK]**.
4. Change with **[ESC]** and **[->]** to the span adjustment

With flow in two directions (bidirectional) a negative differential pressure is also possible. The maximum negative pressure must then be entered for the min. adjustment. For linearization, select "*bidirectional*" or "*bidirectional-extracted by root*" accordingly, see menu item "*Linearization*".

The min. adjustment is finished.

For an adjustment with pressure, simply enter the actual measured value indicated at the bottom of the display.

Max. adjustment flow

Proceed as follows:

1. Select with **[>]** the menu item Max. adjustment and confirm with **[OK]**.



2. Edit the mbar value with **[OK]** and set the cursor to the requested position with **[>]**.
3. Set the requested mbar value with **[+]** and store with **[OK]**.

The max. adjustment is finished.

For an adjustment with pressure, simply enter the actual measured value indicated at the bottom of the display.

Zero adjustment differential pressure

Proceed as follows:

1. Select the menu item "Setup" with **[>]** and confirm with **[OK]**.
Now select with **[>]** the menu item "Zero adjustment" and confirm with **[OK]**.

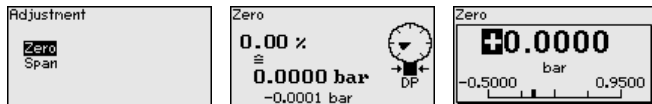

2. Edit the mbar value with **[OK]** and set the cursor to the requested position with **[>]**.
3. Set the requested mbar value with **[+]** and store with **[OK]**.
4. Change with **[ESC]** and **[>]** to the span adjustment

The zero adjustment is finished.



Information:

The Zero adjustment shifts the value of the span adjustment. The span, i.e. the difference between these values, however, remains unchanged.

For an adjustment with pressure, simply enter the actual measured value indicated at the bottom of the display.

Span adjustment differential pressure

Proceed as follows:

1. Select with **[>]** the menu item Span adjustment and confirm with **[OK]**.

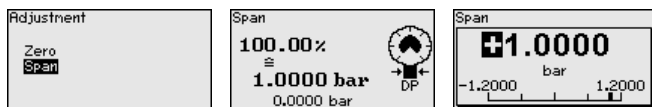

2. Edit the mbar value with **[OK]** and set the cursor to the requested position with **[>]**.

- Set the requested mbar value with **[+]** and store with **[OK]**.

The span adjustment is finished.

For an adjustment with pressure, simply enter the actual measured value indicated at the bottom of the display.

Distance density

Proceed as follows:

- Select in the menu item "Setup" with **[->]** "Adjustment" and confirm with **[OK]**. Now confirm the menu item "Distance" with **[OK]**.

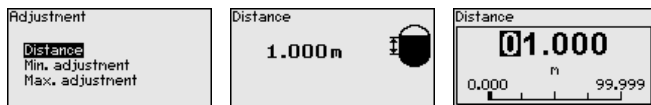

- Edit the sensor distance with **[OK]** and set the cursor to the requested position with **[->]**.
- Set the distance with **[+]** and save with **[OK]**.

The adjustment of the distance is hence finished.

Min. adjustment density

Proceed as follows:

- Select the menu item "Setup" with **[->]** and confirm with **[OK]**. Now select with **[->]** the menu item "Min. adjustment" and confirm with **[OK]**.

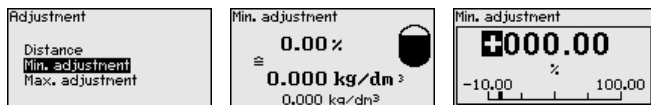

- Edit the percentage value with **[OK]** and set the cursor to the requested position with **[->]**.
- Set the requested percentage value with **[+]** and save with **[OK]**. The cursor jumps now to the density value.
- Enter the min. density corresponding to the percentage value.
- Save settings with **[OK]** and move with **[ESC]** and **[->]** to the max. adjustment.

The min. adjustment for density is finished.

Max. adjustment density

Proceed as follows:

- Select the menu item "Setup" with **[->]** and confirm with **[OK]**. Now select with **[->]** the menu item "Max. adjustment" and confirm with **[OK]**.



- Edit the percentage value with **[OK]** and set the cursor to the requested position with **[->]**.
- Set the requested percentage value with **[+]** and save with **[OK]**. The cursor jumps now to the density value.

- Enter the max. density value corresponding to the percentage value.

The max. adjustment for density is finished.

Distance interface

Proceed as follows:

- Select in the menu item "Setup" with [->] "Adjustment" and confirm with [OK]. Now confirm the menu item "Distance" with [OK].

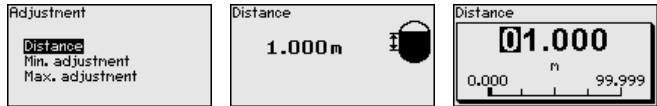

- Edit the sensor distance with [OK] and set the cursor to the requested position with [->].
- Set the distance with [+] and save with [OK].

The adjustment of the distance is hence finished.

Min. adjustment interface

Proceed as follows:

- Select the menu item "Setup" with [->] and confirm with [OK]. Now select with [->] the menu item "Min. adjustment" and confirm with [OK].

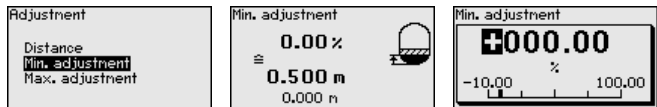

- Edit the percentage value with [OK] and set the cursor to the requested position with [->].
- Set the requested percentage value with [+] and save with [OK]. The cursor jumps now to the height value.
- Enter the min. height of the interface corresponding to the percentage value.
- Save settings with [OK] and move with [ESC] and [->] to the max. adjustment.

The min. adjustment for interface is thus finished.

Max. adjustment interface

Proceed as follows:

- Select the menu item "Setup" with [->] and confirm with [OK]. Now select with [->] the menu item "Max. adjustment" and confirm with [OK].

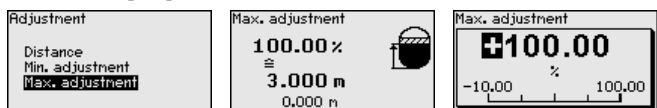

- Edit the percentage value with [OK] and set the cursor to the requested position with [->].
- Set the requested percentage value with [+] and save with [OK]. The cursor jumps now to the height value.

- Enter the max. height of the interface corresponding to the percentage value.

The max. adjustment for interface is finished.

Distance level density-compensated

Proceed as follows:

- Select in the menu item "Setup" with [->] "Adjustment" and confirm with [OK]. Now confirm the menu item "Distance" with [OK].

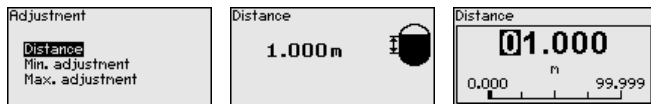

- Edit the sensor distance with [OK] and set the cursor to the requested position with [->].
- Set the distance with [+] and save with [OK].

The adjustment of the distance is hence finished.

Min. adjustment level density-compensated

Proceed as follows:

- Select the menu item "Setup" with [->] and confirm with [OK]. Now select with [->] the menu item "Adjustment", then "Min. adjustment" and confirm with [OK].

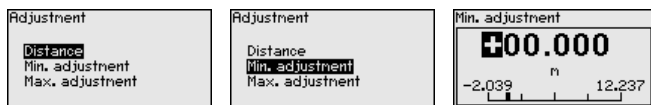

- Edit the percentage value with [OK] and set the cursor to the requested position with [->].
- Set the requested percentage value (e.g. 0 %) with [+] and save with [OK]. The cursor jumps now to the pressure value.
- Enter the value corresponding to the min. level (e.g. 0 m).
- Save settings with [OK] and move with [ESC] and [->] to the max. adjustment.

The min. adjustment is finished.

For an adjustment with filling, simply enter the actual measured value indicated at the bottom of the display.

Max. adjustment level density-compensated

Proceed as follows:

- Select with [->] the menu item Max. adjustment and confirm with [OK].

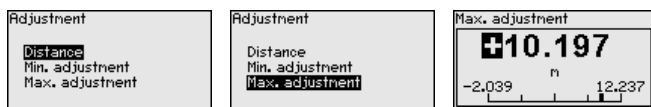

- Edit the percentage value with [OK] and set the cursor to the requested position with [->].
- Set the requested percentage value (e.g. 100 %) with [+] and save with [OK]. The cursor jumps now to the pressure value.

4. Enter the value for the full vessel (e.g. 10 m) corresponding to the percentage value.
5. Save settings with **[OK]**

The max. adjustment is finished.

For an adjustment with filling, simply enter the actual measured value indicated at the bottom of the display.

Linearisation

A linearization is necessary for all applications in which the measured process variable does not increase linearly with the measured value. This applies for example to the flow measured via the differential pressure or the vessel volume measured via the level. Corresponding linearization curves are preprogrammed for such cases. They represent the correlation between the measured value percentage and process variable. The linearization applies to the measured value indication and the current output.

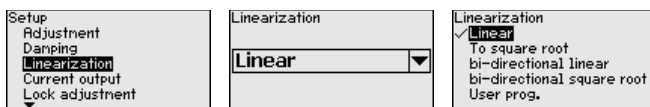

With flow measurement and selection "Linear" display and output (percentage/current) are linear to "Differential pressure". This can be used, for example, to feed a flow computer.

With flow measurement and selection "Extraction by root" display and output (percentage/current) are linear to "Flow".⁴⁾

With flow in two directions (bidirectional) a negative differential pressure is also possible. This must already be taken into account in menu item "Min. adjustment flow".



Caution:

Note the following, if the respective sensor is used as part of an over-fill protection system according to WHG:

If a linearisation curve is selected, the measuring signal is no longer necessarily linear to the filling height. This must be considered by the user especially when setting the switching point on the limit signal transmitter.

AI FB1

Since the parameter adjustment of the Function Block 1 (FB1) is very comprehensive, it was divided into various submenu items.

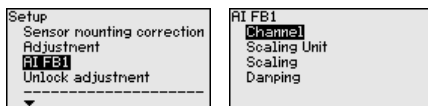

AI FB1 - Channel

In menu item "Channel" you determine the input signal for further processing in AI FB 1.

As input signals, the output values of Transducer Block (TB) can be selected.

⁴⁾ The device assumes an approximately constant temperature and static pressure and calculates the flow rate from the measured differential pressure using the characteristic curve extracted by root.

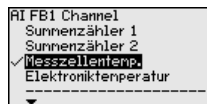
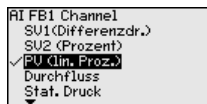
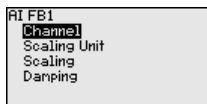

6.1.2 Display

Display value 1 and 2 - 4 ... 20 mA

In this menu item, you define which measured value is displayed.

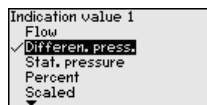
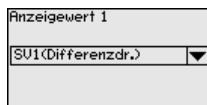
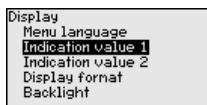

The default setting for the displayed value is "Differential pressure".

Display format 1 and 2

In this menu item you define the number of decimal positions with which the measured value is displayed.

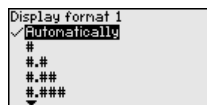
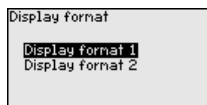
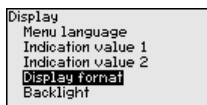

The default setting for the display format is "Automatic".

Display value 1 and 2 - bus systems

In this menu item, you define which measured value is displayed.

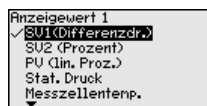
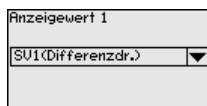
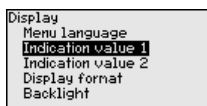

The default setting for the displayed value is "Differential pressure".

Display format 1 and 2

In this menu item you define the number of decimal positions with which the measured value is displayed.

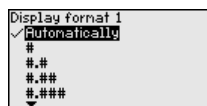
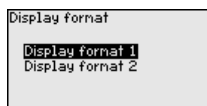
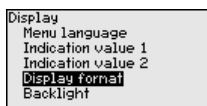

The default setting for the display format is "Automatic".

6.1.3 Diagnostics

Peak value, pressure

The respective min. and max. measured values for the differential pressure and static pressure are stored in the sensor. In menu item "Peak value, pressure", both values are displayed.

In another window you can carry out a reset of the peak values separately.

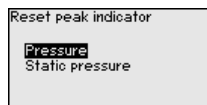
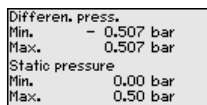
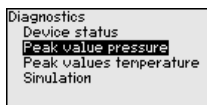

**Simulation 4 ... 20 mA/
HART**

In this menu item you can simulate measured values. This allows the signal path to be tested, e.g. through downstream indicating instruments or the input card of the control system.

Diagnostics Device status Peak value pressure Peak values temperature Simulation	Simulation Flow Differen. press. Stat. pressure Percent Current output ▼	Simulation Activate simulation?
Simulation running Pressure 0.0000 bar	Simulation running 0.0000 bar -0,5000 1,5000	Simulation Deactivate simulation?

Select the requested simulation variable and set the requested value.

To deactivate the simulation, you have to push the **[ESC]** key and confirm the message "Deactivate simulation" with the **[OK]** key.

**Caution:**

During simulation, the simulated value is output as 4 ... 20 mA current value and as digital HART signal. The status message within the context of the asset management function is "Maintenance".

**Note:**

Without manual deactivation, the sensor terminates the simulation automatically after 60 minutes.

Simulation bus systems

In this menu item you can simulate measured values. This allows the signal path to be tested, e.g. through downstream indicating instruments or the input card of the control system.

Diagnostics Device status Peak value pressure Peak values temperature Simulation	Simulation SU1(Differenzdr.) SU2 (Prozent) PU (lin. Proz.) Stat. Druck Messzellentemp. ▼	Simulation Activate simulation?
Simulation running Pressure 0.0000 bar	Simulation running 0.0000 bar -0,5000 1,5000	Simulation Deactivate simulation?

Select the requested simulation variable and set the requested value.

To deactivate the simulation, you have to push the **[ESC]** key and confirm the message "Deactivate simulation" with the **[OK]** key.

**Caution:**

During simulation, the simulated value is output as digital signal. The status message along with the Asset Management function is "Maintenance".

**Note:**

Without manual deactivation, the sensor terminates the simulation automatically after 60 minutes.

6.1.4 Additional adjustments

Current output 1 and 2 (size)

In menu item "*Current output, variable*" you specify which measured variable is output via the current output.

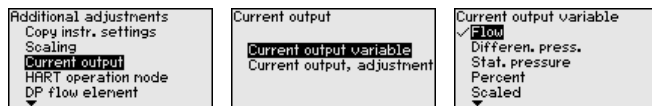

The following selection is possible depending on the selected application:

- Flow
- Height - Interface
- Density
- Differential pressure
- Static pressure
- Percent
- Scaled
- Percent linearized
- Measuring cell temperature (ceramic measuring cell)
- Electronics temperature

Characteristics values DP flow element

In this menu item, the units for the DP flow element are determined and the selection of mass or volume flow is carried out.

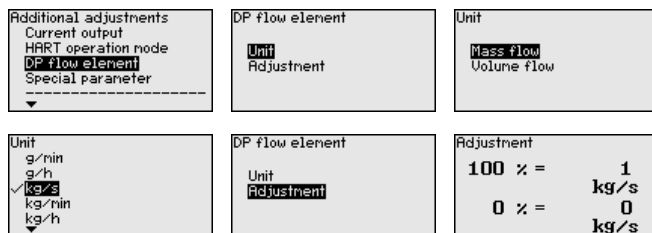

Furthermore the adjustment for the volume or mass flow at 0 % or 100 % is carried out.

The device automatically adds the flow in the selected unit. With appropriate adjustment and bidirectional linearization, the flow rate is counted both positively and negatively.

7 Diagnosis, asset management and service

7.1 Maintenance

Maintenance

If the device is used properly, no special maintenance is required in normal operation.

Precaution measures against buildup

In some applications, product buildup on the diaphragm can influence the measuring result. Depending on the sensor and application, take precautions to ensure that heavy buildup, and especially a hardening thereof, is avoided.

Cleaning

The cleaning helps that the type label and markings on the instrument are visible.

Take note of the following:

- Use only cleaning agents which do not corrode the housings, type label and seals
- Use only cleaning methods corresponding to the housing protection rating

7.2 Cleaning - hygienic connection with compression nut

Overview

The hygienic connection with compression nut can be disassembled and the diaphragm cleaned.

The following graphic shows the structure:

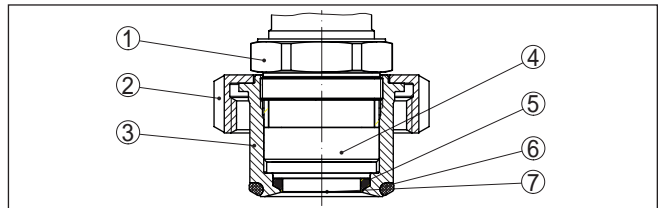

Fig. 29: CPT-2x, structure of the hygienic connection with compression nut

- 1 Hexagon
- 2 Compression nut
- 3 Process fitting
- 4 Process module
- 5 Form seal for the measuring cell
- 6 O-ring seal for the process fitting
- 7 Diaphragm

Procedure

To do so, proceed as follows:

1. Loosen compression nut and remove the pressure transmitter from the welded socket
2. Remove the O-ring seal for the process fitting
3. Clean the diaphragm with brass brush and cleaning detergent
4. Loosen the hexagon and remove the process component from the process fitting

5. Remove the form seal for the measuring cell and remove it by a new one
6. Screw the process component into the process fitting, tighten the hexagon (wrench size see chapter "*Dimensions*", max. torque see chapter "*Technical data*")
7. Insert new O-ring seal for the process fitting
8. Install the process pressure transmitter in the welded socket, tighten compression nut

The cleaning is finished.

The pressure transmitter is directly ready for operation, a fresh adjustment is not required.

7.3 Rectify faults

Reaction when malfunction occurs

The operator of the system is responsible for taking suitable measures to rectify faults.

Fault rectification

The first measures are:

- Evaluation of fault messages
- Checking the output signal
- Treatment of measurement errors

Further comprehensive diagnostics options are available with a PC/notebook with PACTware and the suitable DTM. In many cases, the reasons can be determined in this way and faults rectified.

Reaction after fault rectification

Depending on the reason for the fault and the measures taken, the steps described in chapter "*Setup*" must be carried out again or must be checked for plausibility and completeness.

7.4 Exchange process module on version IP68 (25 bar)

On version IP68 (25 bar), the user can exchange the process module on site. Connection cable and external housing can be kept.

Required tools:

- Hexagon key wrench, size 2



Caution:

The exchange may only be carried out in the complete absence of line voltage.



In Ex applications, only a replacement part with appropriate Ex approval may be used.



Caution:

During exchange, protect the inner side of the parts against contamination and moisture.

Proceed as follows when carrying out the exchange:

1. Loosen the fixing screw with the hexagon key wrench
2. Carefully detach the cable assembly from the process module

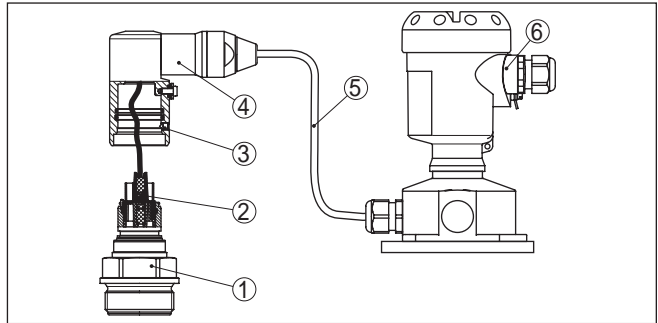

Fig. 30: CPT-2x in IP68 version, 25 bar and lateral cable outlet, external housing

- 1 Process module
- 2 Plug connector
- 3 Fixing screw
- 4 Cable assembly
- 5 Connection cable
- 6 External housing

3. Loosen the plug connector
 4. Mount the new process module on the measuring point
 5. Plug the connector back in
 6. Mount the cable assembly on the process module and turn it to the desired position
 7. Tighten the fixing screw with the hexagon key wrench
- The exchange is finished.

7.5 Instrument repair

You can find information for a return shipment under "Service" on our local website.

If a repair is necessary, please proceed as follows:

- Complete one form for each instrument
- If necessary, state a contamination
- Clean the instrument and pack it damage-proof
- Attach the completed form and possibly also a safety data sheet to the instrument

8 Dismount

8.1 Dismounting steps

**Warning:**

Before dismantling, be aware of dangerous process conditions such as e.g. pressure in the vessel or pipeline, high temperatures, corrosive or toxic media etc.

Take note of chapters "*Mounting*" and "*Connecting to voltage supply*" and carry out the listed steps in reverse order.

8.2 Disposal

The instrument consists of materials which can be recycled by specialised recycling companies. We use recyclable materials and have designed the electronics to be easily separable.

WEEE directive

The instrument does not fall in the scope of the EU WEEE directive. Article 2 of this Directive exempts electrical and electronic equipment from this requirement if it is part of another instrument that does not fall in the scope of the Directive. These include stationary industrial plants.

Pass the instrument directly on to a specialised recycling company and do not use the municipal collecting points.

If you have no way to dispose of the old instrument properly, please contact us concerning return and disposal.

9 Supplement

9.1 Technical data

Note for approved instruments

The technical data in the respective safety instructions which are included in delivery are valid for approved instruments (e.g. with Ex approval). These data can differ from the data listed herein, for example regarding the process conditions or the voltage supply.

All approval documents can be downloaded from our homepage.

Materials and weights

Materials, wetted parts

Process fitting	316L, PVDF, Alloy C22 (2.4602), Alloy C276 (2.4819), Duplex (1.4462), Titanium Grade 2
Diaphragm	Sapphire-ceramic® (> 99.9 % Al ₂ O ₃ ceramic)
Joining material, diaphragm/base element of measuring cell	Glass (with double and form seal, non-wetted parts)
Measuring cell seal	FKM (VP2/A, A+P 70.16), EPDM (A+P 70.10-02), FFKM (Kalrez 6375, Perlast G75S, Perlast G75B)
Seal for process fitting (in the scope of delivery)	
– Thread G $\frac{1}{2}$ (EN 837), G1 $\frac{1}{2}$ (DIN 3852-A)	Klingersil C-4400
– Hygienic connection with compression nut	FKM, EPDM, FFKM, FEPM
– M44 x 1.25 (DIN 13), M30 x 1.5	FKM, FFKM, EPDM

Materials for applications in foodstuffs

Surface quality, hygienic fittings, typ.

– Process fitting	R _a < 0.8 μm
– Ceramic diaphragm	R _a < 0.5 μm

Seal below wall mounting plate with 3A approval EPDM

Materials, non-wetted parts

Housing

– Plastic housing	Plastic PBT (Polyester)
– Aluminium die-cast housing	Aluminium die-casting AlSi10Mg, powder-coated (Basis: Polyester)
– Stainless steel housing	316L
– Cable gland	PA, stainless steel, brass
– Sealing, cable gland	NBR
– Blind plug, cable gland	PA
– Seal between housing and housing lid	Silicone SI 850 R, NBR silicone-free
– Inspection window housing cover	Polycarbonate (UL-746-C listed), glass ⁵⁾
– Ground terminal	316L

⁵⁾ Glass with Aluminium and stainless steel precision casting housing

External housing

– Housing	Plastic PBT (Polyester), 316L
– Socket, wall mounting plate	Plastic PBT (Polyester), 316L
– Seal between base and wall mounting plate	EPDM (fixed connected)
Inspection window in housing cover	Polycarbonate, UL746-C listed (with Ex-d version: glass)
Seal between housing and housing lid	Silicone SI 850 R, NBR silicone-free, EPDM (coating-compatible)
Ground terminal	316Ti/316L
Connection cable to the master sensor	PE, PUR

Weights

Total weight CPT-2x	approx. 0.8 ... 8 kg (1.764 ... 17.64 lbs), depending on process fitting and housing
---------------------	--

Torques

Max. torque for process fitting

– G½, G¾	30 Nm (22.13 lbf ft)
– Fittings according to 3A with exchangeable sealing	20 Nm (14.75 lbf ft)
– Hygienic fitting with compression nut (hexagon)	40 Nm (29.50 lbf ft)
– G1, M30 x 1.5	50 Nm (36.88 lbf ft)
– G1 for PASVE	100 Nm (73.76 lbf ft)
– G1½	200 Nm (147.5 lbf ft)

Max. torque for screws

– PMC 1", PMC 1¼"	2 Nm (1.475 lbf ft)
– PMC 1½"	5 Nm (3.688 lbf ft)

Max. torque for NPT cable glands and Conduit tubes

– Plastic housing	10 Nm (7.376 lbf ft)
– Aluminium/Stainless steel housing	50 Nm (36.88 lbf ft)

Input variable

The specifications are only an overview and refer to the measuring cell. Limitations due to the material and version of the process fitting as well as the selected pressure type are possible. The specifications on the nameplate apply.⁶⁾

Nominal measuring ranges and overload capability in bar/kPa

Nominal range	Overload capability	
	Maximum pressure	Minimum pressure
Gauge pressure		

⁶⁾ Data on overload capability apply for reference temperature.

Nominal range	Overload capability	
	Maximum pressure	Minimum pressure
0 ... +0.025 bar/0 ... +2.5 kPa (only for measuring cell ø 28 mm)	+5 bar/+500 kPa	-0.05 bar/-5 kPa
0 ... +0.1 bar/0 ... +10 kPa	+15 bar/+1500 kPa	-0.2 bar/-20 kPa
0 ... +0.4 bar/0 ... +40 kPa	+30 bar/+3000 kPa	-0.8 bar/-80 kPa
0 ... +1 bar/0 ... +100 kPa	+35 bar/+3500 kPa	-1 bar/-100 kPa
0 ... +2.5 bar/0 ... +250 kPa	+50 bar/+5000 kPa	-1 bar/-100 kPa
0 ... +5 bar/0 ... +500 kPa	+65 bar/+6500 kPa	-1 bar/-100 kPa
0 ... +10 bar/0 ... +1000 kPa	+90 bar/+9000 kPa	-1 bar/-100 kPa
0 ... +25 bar/0 ... +2500 kPa	+125 bar/+12500 kPa	-1 bar/-100 kPa
0 ... +60 bar/0 ... +6000 kPa	+200 bar/+20000 kPa	-1 bar/-100 kPa
0 ... +100 bar/0 ... +10000 kPa (only for measuring cell ø 28 mm)	+200 bar/+20000 kPa	-1 bar/-100 kPa
-1 ... 0 bar/-100 ... 0 kPa	+35 bar/+3500 kPa	-1 bar/-100 kPa
-1 ... +1.5 bar/-100 ... +150 kPa	+40 bar/+4000 kPa	-1 bar/-100 kPa
-1 ... +10 bar/-100 ... +1000 kPa	+90 bar/+9000 kPa	-1 bar/-100 kPa
-1 ... +25 bar/-100 ... +2500 kPa	+125 bar/+12500 kPa	-1 bar/-100 kPa
-1 ... +60 bar/-100 ... +6000 kPa	+200 bar/+20000 kPa	-1 bar/-100 kPa
-1 ... +100 bar/-100 ... +10000 kPa (only for measuring cell ø 28 mm)	+200 bar/+20000 kPa	-1 bar/-100 kPa
-0.025 ... +0.025 bar/-2.5 ... +2.5 kPa	+5 bar/+500 kPa	-0.05 bar/-5 kPa
-0.05 ... +0.05 bar/-5 ... +5 kPa	+15 bar/+1500 kPa	-0.2 bar/-20 kPa
-0.2 ... +0.2 bar/-20 ... +20 kPa	+20 bar/+2000 kPa	-0.4 bar/-40 kPa
-0.5 ... +0.5 bar/-50 ... +50 kPa	+35 bar/+3500 kPa	-1 bar/-100 kPa
Absolute pressure		
0 ... 0.1 bar/0 ... 10 kPa	15 bar/1500 kPa	0 bar abs.
0 ... 1 bar/0 ... 100 kPa	35 bar/3500 kPa	0 bar abs.
0 ... 2.5 bar/0 ... 250 kPa	50 bar/5000 kPa	0 bar abs.
0 ... +5 bar/0 ... +500 kPa	65 bar/+6500 kPa	0 bar abs.
0 ... 10 bar/0 ... 1000 kPa	90 bar/9000 kPa	0 bar abs.
0 ... 25 bar/0 ... 2500 kPa	125 bar/12500 kPa	0 bar abs.
0 ... 60 bar/0 ... 6000 kPa	200 bar/20000 kPa	0 bar abs.
0 ... 100 bar/0 ... +10000 kPa (only for measuring cell ø 28 mm)	200 bar/20000 kPa	0 bar abs.

Nominal measuring ranges and overload capacity in psi

Nominal range	Overload capability	
	Maximum pressure	Minimum pressure
Gauge pressure		
0 ... +0.4 psig (only for measuring cell ø 28 mm)	+75 psig	-0.7 psig
0 ... +1.5 psig	+225 psig	-3 psig
0 ... +5 psig	+375 psig	-11.50 psig
0 ... +15 psig	+525 psig	-14.51 psig
0 ... +30 psig	+725 psig	-14.51 psig
0 ... +75 psig	+975 psig	-14.51 psig
0 ... +150 psig	+1350 psig	-14.51 psig
0 ... +300 psig	+1900 psig	-14.51 psig
0 ... +900 psig	+2900 psig	-14.51 psig
0 ... +1450 psig (only for measuring cell ø 28 mm)	+2900 psig	-14.51 psig
-14.5 ... 0 psig	+525 psig	-14.51 psig
-14.5 ... +20 psig	+600 psig	-14.51 psig
-14.5 ... +75 psig	+975 psig	-14.51 psig
-14.5 ... +150 psig	+1350 psig	-14.51 psig
-14.5 ... +300 psig	+1900 psig	-14.51 psig
-14.5 ... +900 psig	+2900 psig	-14.51 psig
-14.5 ... +1500 psig (only for measuring cell ø 28 mm)	+2900 psig	-14.51 psig
-0.7 ... +0.7 psig	+75 psig	-2.901 psig
-3 ... +3 psig	+225 psi	-5.800 psig
-7 ... +7 psig	+525 psig	-14.51 psig
Absolute pressure		
0 ... 1.5 psi	225 psig	0 psi
0 ... 15 psi	525 psi	0 psi
0 ... 30 psi	725 psi	0 psi
0 ... 75 psi	975 psi	0 psi
0 ... 150 psi	1350 psi	0 psi
0 ... 300 psi	1900 psi	0 psi
0 ... 900 psi	2900 psi	0 psi
0 ... 1450 psi (only for measuring cell ø 28 mm)	2900 psi	0 psi

Adjustment ranges

Specifications refer to the nominal measuring range, pressure values lower than -1 bar cannot be set

Level (min./max. adjustment)

– Percentage value

-10 ... 110 %

– Pressure value -120 ... 120 %

Flow (min./max. adjustment)

– Percentage value 0 or 100 % fix

– Pressure value -120 ... 120 %

Differential pressure (zero/span adjustment)

– Zero -95 ... +95 %

– Span -120 ... +120 %

Density (min./max. adjustment)

– Percentage value -10 ... 100 %

– Density value according to the measuring ranges in kg/dm³

Interface (min./max. adjustment)

– Percentage value -10 ... 100 %

– Level value according to the measuring ranges in m

Max. permissible Turn Down Unlimited (recommended 20 : 1)

Dynamic behaviour output

Dynamic characteristics depending on medium and temperature

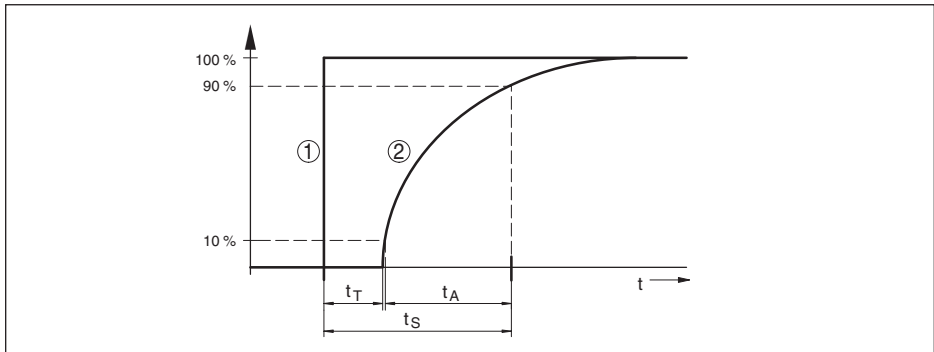

Fig. 31: Behaviour in case of sudden change of the process variable. t_T : dead time; t_A : rise time; t_S : jump response time

1 Process variable

2 Output signal

	CPT-2x	CPT-2x - IP68 (25 bar)
Dead time	≤ 25 ms	≤ 50 ms
Rise time (10 ... 90 %)	≤ 55 ms	≤ 150 ms
Step response time (ti: 0 s, 10 ... 90 %)	≤ 80 ms	≤ 200 ms

Damping (63 % of the input variable) 0 ... 999 s, adjustable via menu item "Damping"

Reference conditions and influencing variables (according to DIN EN 60770-1)

Reference conditions according to DIN EN 61298-1

- Temperature +15 ... +25 °C (+59 ... +77 °F)
- Relative humidity 45 ... 75 %
- Air pressure 860 ... 1060 mbar/86 ... 106 kPa (12.5 ... 15.4 psig)

Determination of characteristics Limit point adjustment according to IEC 61298-2

Characteristic curve Linear

Reference installation position upright, diaphragm points downward

Influence of the installation position < 0.2 mbar/20 Pa (0.003 psig)

Deviation in the current output due to strong, high-frequency electromagnetic fields acc. to EN 61326-1 < ±150 µA

Deviation (according to IEC 60770-1)

Specifications refer to the set span. Turn down (TD) is the ratio: nominal measuring range/set span.

Accuracy class	Non-linearity, hysteresis and repeatability with TD 1 : 1 up to 5 : 1	Non-linearity, hysteresis and repeatability with 5 : 1
0.05 %	< 0.05 %	< 0.01 % x TD
0.1 %	< 0.1 %	< 0.02 % x TD
0.2 %	< 0.2 %	< 0.04 % x TD

Influence of the product temperature**Thermal change zero signal and output span through product temperature**

Refers to the set span. Turn down (TD) is the ratio: nominal measuring range/set span.

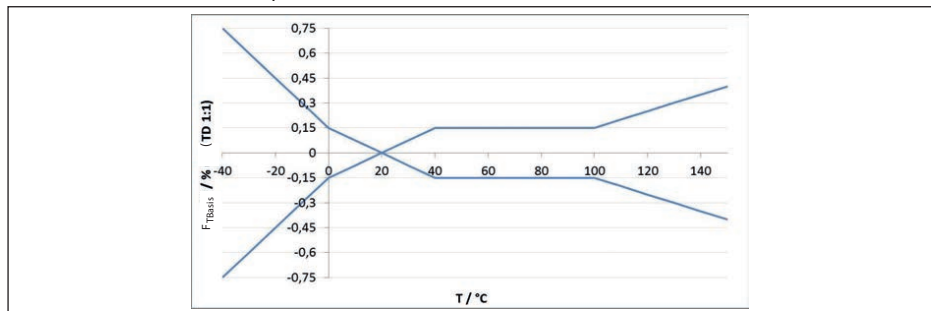
The thermal change of the zero signal and output span corresponds to the temperature error F_T in chapter "Calculation of the total deviation (according to DIN 16086)".**Basic temperature error F_T** Fig. 32: Basic temperature error F_{TBasis} at TD 1 : 1

The basic temperature error in % from the above graphic can increase due to the additional factors, depending on the measuring cell version (factor FMZ) and the Turn Down (factor FTD). The additional factors are listed in the following tables.

Additional factor through measuring cell version

Measuring cell version	Measuring cell standard, depending on the accuracy class		
	0.05 %, 0.1 %	0.2 % (with measuring range 0.1 bar _{abs})	0.2 % 0.05 %, 0.1 % with measuring range 25 mbar
Factor FMZ	1	2	3

Additional factor through Turn Down

The additional factor FTD through Turn down is calculated according to the following formula:

$$F_{TD} = 0.5 \times TD + 0.5$$

In the table, example values for typical Turn downs are listed.

Turn Down	TD 1 : 1	TD 2.5 : 1	TD 5 : 1	TD 10 : 1	TD 20 : 1
Factor FTD	1	1.75	3	5.5	10.5

Long-term stability (according to DIN 16086)

Applies to the respective **digital** signal output (e.g. HART, Profibus PA) as well as to **analogue** current output 4 ... 20 mA under reference conditions. Specifications refer to the set span. Turn down (TD) is the ratio nominal measuring range/set span.

Long-term stability zero signal and output span

Time period	Measuring cell \varnothing 28 mm		Measuring cell \varnothing 17.5 mm	
	Measuring ranges from 0 ... +0.1 bar (0 ... +10 kPa)	Measuring range 0 ... +0.025 bar (0 ... +2.5 kPa)	All process fittings ⁷⁾	Process fitting G $\frac{1}{2}$ (ISO 228-1)
One year	< 0.05 % x TD	< 0.1 % x TD	< 0.1 % x TD	< 0.25 % x TD
Five years	< 0.1 % x TD	< 0.2 % x TD	< 0.2 % x TD	< 0.5 % x TD
Ten years	< 0.2 % x TD	< 0.4 % x TD	< 0.4 % x TD	< 1 % x TD

⁷⁾ without process fitting G $\frac{1}{2}$ (ISO 228-1)

Process conditions

Process temperature⁸⁾

Measuring cell seal		Sensor version	
		Standard	Extended temperature range ⁹⁾
FKM	VP2/A	-20 ... +130 °C (-4 ... +266 °F)	-20 ... +150 °C (-4 ... +302 °F)
	A+P 70.16	-40 ... +130 °C (-40 ... +266 °F)	-
	Endura V91A	-40 ... +130 °C (-40 ... +266 °F)	-40 ... +150 °C (-40 ... +302 °F)
	ET 7067	-20 ... +130 °C (-4 ... +266 °F)	-
	V70SW	-	-10 ... +150 °C (14 ... +302 °F)
EPDM	A+P 70.10-02	-40 ... +130 °C (-40 ... +266 °F)	-40 ... +150 °C (-40 ... +302 °F)
	ET 7056	-40 ... +130 °C (-40 ... +266 °F)	-
	E70Q	-	-40 ... +150 °C (-40 ... +302 °F)
	Fluoraz SD890	-5 ... +130 °C (-22 ... +266 °F)	-
FFKM	Kalrez 6375	-20 ... +130 °C (-4 ... +266 °F)	-20 ... +150 °C (-4 ... +302 °F)
	Perlast G75S	-15 ... +130 °C (-4 ... +266 °F)	-15 ... +150 °C (5 ... +302 °F)
	Perlast G75B	-15 ... +130 °C (-4 ... +266 °F)	-15 ... +150 °C (5 ... +302 °F)
	Perlast G92E	-15 ... +130 °C (-4 ... +266 °F)	-15 ... +150 °C (5 ... +302 °F)
	Chemraz 535	-30 ... +130 °C (-22 ... +266 °F)	-

Temperature derating

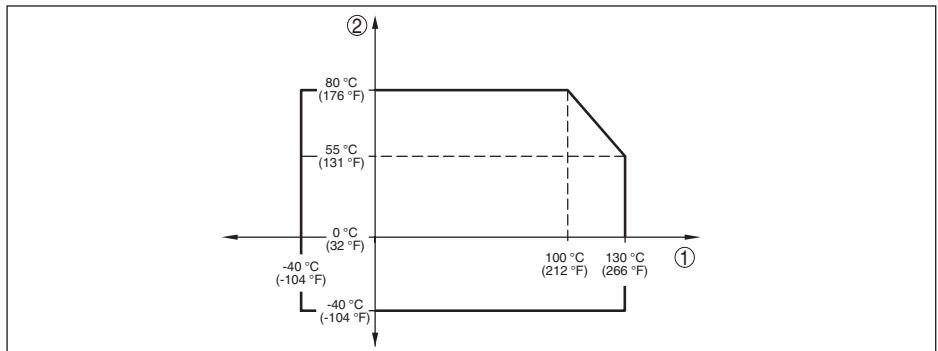

Fig. 33: Temperature derating CPT-2x, version up to +130 °C (+266 °F)

- 1 Process temperature
- 2 Ambient temperature

⁸⁾ With process fitting PVDF, process temperature max. 100 °C (212 °F).

¹⁾ Measuring cell ø 28 mm

⁹⁾ Measuring cell ø 28 mm

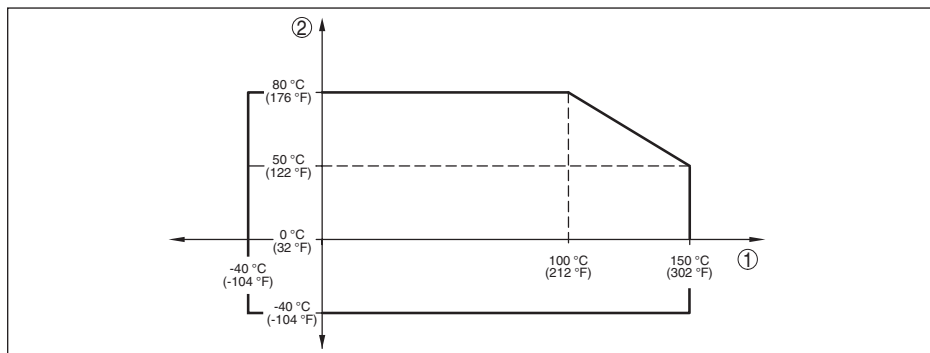

Fig. 34: Temperature derating CPT-2x, version up to +150 °C (+302 °F)

- 1 Process temperature
2 Ambient temperature

SIP process temperature (SIP = Sterilization in place)

Applies to instruments configurations suitable for vapour, i.e. material measuring cell seal EPDM or FFKM (Perlast G75S).

Vapour stratification up to 2 h +150 °C (+302 °F)

Process pressure

Permissible process pressure see specification "process pressure" on the type label

Mechanical stress¹⁰⁾

Vibration resistance 4 g at 5 ... 200 Hz according to EN 60068-2-6 (vibration with resonance)

Shock resistance 50 g, 2.3 ms according to EN 60068-2-27 (mechanical shock)¹¹⁾

Ambient conditions

Version	Ambient temperature	Storage and transport temperature
Standard version	-40 ... +80 °C (-40 ... +176 °F)	-60 ... +80 °C (-76 ... +176 °F)
Version IP66/IP68 (1 bar)	-20 ... +80 °C (-4 ... +176 °F)	-20 ... +80 °C (-4 ... +176 °F)
Version IP68 (25 bar), with connection cable PUR	-20 ... +80 °C (-4 ... +176 °F)	-20 ... +80 °C (-4 ... +176 °F)
Version IP68 (25 bar), connection cable PE	-20 ... +60 °C (-4 ... +140 °F)	-20 ... +60 °C (-4 ... +140 °F)

Electromechanical data - version IP66/IP67 and IP66/IP68 (0.2 bar)¹²⁾

Options of the cable entry

- Cable entry M20 x 1.5; ½ NPT
- Cable gland M20 x 1.5; ½ NPT (cable diameter see below table)
- Blind plug M20 x 1.5; ½ NPT

¹⁰⁾ Depending on the instrument version.

¹¹⁾ 2 g with housing version stainless steel double chamber

¹²⁾ IP66/IP68 (0.2 bar), only with absolute pressure.

– Closing cap ½ NPT

Material cable gland/Seal insert	Cable diameter		
	5 ... 9 mm	6 ... 12 mm	7 ... 12 mm
PA/NBR	●	●	–
Brass nickel-plated/NBR	●	●	–
Stainless steel/NBR	–	–	●

Wire cross-section (spring-loaded terminals)

- Massive wire, stranded wire 0.2 ... 2.5 mm² (AWG 24 ... 14)
- Stranded wire with end sleeve 0.2 ... 1.5 mm² (AWG 24 ... 16)

Electromechanical data - version IP68 (25 bar)

Connection cable transmitter - external housing, mechanical data

- Configuration Wires, strain relief, breather capillaries, screen braiding, metal foil, mantle¹³⁾
- Standard length 5 m (16.40 ft)
- Max. length 180 m (590.5 ft)
- Min. bending radius at 25 °C/77 °F 25 mm (0.985 in)
- Diameter approx. 8 mm (0.315 in)
- Material PE, PUR
- Colour Black, blue

Connection cable transmitter - external housing, electrical data

- Wire cross-section 0.5 mm² (AWG 20)
- Wire resistance 0.037 Ω/m (0.012 Ω/ft)

Interface to the Master sensor

Data transmission Digital (I²C-Bus)

Connection cable Slave - Master, mechanical data

- Configuration Cores, strain relief, braided, metal foil, jacket
- Standard length 5 m (16.40 ft)
- Max. length 25 m (82.02 ft)
- Min. bending radius (at 25 °C/77 °F) 25 mm (0.985 in)
- Diameter approx. 8 mm (0.315 in), approx. 6 mm (0.236 in)
- Material PE, PUR
- Colour Black

Connection cable Slave - Master, electrical data

- Wire cross-section 0.34 mm² (AWG 22)
- Wire resistance < 0.05 Ω/m (0.015 Ω/ft)

¹³⁾ Breather capillaries not with Ex-d version.

Voltage supply for the complete system through Master

Operating voltage

- $U_{B \min}$ 12 V DC
- $U_{B \min}$ with lighting switched on 16 V DC
- $U_{B \max}$ Depending on signal output and version of the master sensor

Potential connections and electrical separating measures in the instrument

Electronics	Not non-floating
Reference voltage ¹⁴⁾	500 V AC
Conductive connection	Between ground terminal and metallic process fitting

Electrical protective measures

Housing material	Version	Protection acc. to IEC 60529	Protection acc. to NEMA
Plastic	Single chamber	IP66/IP67	Type 4x
Aluminium		IP66/IP67	Type 4x
		IP66/IP68 (0.2 bar)	Type 6P
Stainless steel (electro-polished)		IP66/IP67	Type 4x
		IP69K	-
Stainless steel (precision casting)		IP66/IP67	Type 4x
		IP66/IP68 (0.2 bar)	Type 6P
Stainless steel	Transmitter for external housing	IP68 (25 bar)	-

Altitude above sea level

- by default up to 2000 m (6562 ft)
- with connected overvoltage protection up to 5000 m (16404 ft) on the master sensor

Pollution degree¹⁵⁾ 4

Protection rating (IEC 61010-1) II

9.2 Calculation of the total deviation

The total deviation of a pressure transmitter indicates the maximum measurement error to be expected in practice. It is also called maximum practical deviation or operational error.

According to DIN 16086, the total deviation F_{total} is the sum of the basic deviation F_{perf} and the long-term stability F_{stab} :

$$F_{\text{total}} = F_{\text{perf}} + F_{\text{stab}}$$

The basic deviation F_{perf} consists of the thermal change of the zero signal and the output span F_T as well as the deviation F_{K1} :

$$F_{\text{perf}} = \sqrt{((F_T)^2 + (F_{K1})^2)}$$

The thermal change of zero signal and output span F_T is specified in chapter "Technical data". The

¹⁴⁾ Galvanic separation between electronics and metal housing parts

¹⁵⁾ When used with fulfilled housing protection.

basic temperature error F_T is shown in a graphic. Depending on the measuring cell version and Turn down, this value must be multiplied with the additional factors FMZ and FTD:

$$F_T \times FMZ \times FTD$$

Also these values are specified in chapter "Technical data".

This applies for a digital signal output through HART, Profibus PA or Foundation Fieldbus.

With a 4 ... 20 mA output, the thermal change of the current output F_a must be added:

$$F_{perf} = \sqrt{((F_T)^2 + (F_{KI})^2 + (F_a)^2)}$$

To provide a better overview, the formula symbols are listed together below:

- F_{total} : Total deviation
- F_{perf} : Basic deviation
- F_{stab} : Long-term stability
- F_T : Thermal change of zero signal and output span (temperature error)
- F_{KI} : Deviation
- F_a : Thermal change of the current output
- FMZ: Additional factor measuring cell version
- FTD: Additional factor Turn down

9.3 Practical example

Data

Level measurement in a small vessel, 500 mm height corresponds to 0.049 bar (4.9 KPa), superimposed pressure 0.35 bar (35 KPa), medium temperature 40 °C

CPT-2x Master and slave sensor each with nominal measuring range 0.4 bar (40 KPa), deviation < 0.1 %, process fitting G1½ (measuring cell ø 28 mm)

The required values for the temperature error F_T , deviation F_{KI} and long-term stability F_{stab} are available in the technical data.

1. Calculation of the Turn down

$$TD = 0.4 \text{ bar} / 0.049 \text{ bar}, TD = 8.2 : 1$$

2. Determination temperature error F_T

The temperature error F_T consists of the basic temperature error F_{TBasis} , the additional factor measuring cell F_{MZ} and the additional factor Turn Down F_{TD} .

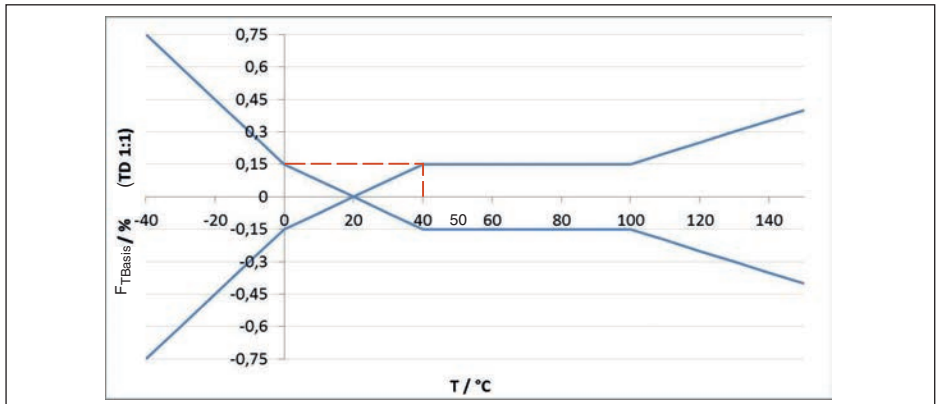

Fig. 35: Determination of the basic temperature error for the above example: $F_{TBasis} = 0.15 \%$

Measuring cell version	Measuring cell standard, depending on the accuracy class		
	0.05 %, 0.1 %	0.2 % (0.1 bar _{abs})	0.2 %
Factor FMZ	1	2	3

Tab. 13: Determination of the additional factor measuring cell for above example: $F_{MZ} = 1$

The additional factor FTD through Turn down is calculated according to the following formula:

$F_{TD} = 0.5 \times TD + 0.5$, with TD = 8.2:1 of above calculation

$F_{TD} = 0.5 \times 8.2 + 0.5 = 4.6$

Determination of the temperature error master sensor for above example:

$F_T = F_{TBasis} \times F_{MZ} \times F_{TD}$

$F_T = 0.15 \% \times 1 \times 4.6$

$F_T = 0.69 \%$

The temperature error of each sensor is hence 0.69 %

3. Determination of deviation and long-term stability

Accuracy class	Non-linearity, hysteresis and non-repeatability	
	TD ≤ 5 : 1	TD > 5 : 1
0.05 %	< 0.05 %	< 0.01 % x TD
0.1 %	< 0.1 %	< 0.02 % x TD
0.2 %	< 0.2 %	< 0.04 % x TD

Tab. 14: Determination of the deviation F_{KI} from the table with accuracy class 0.1 %: $F_{KI} = 0.02 \% \times TD = 0.02 \% \times 8.2 = 0.16 \%$

Time period	Measuring cell ø 28 mm		Measuring cell ø 17.5 mm	
	All measuring ranges	Measuring range 0 ... +0.025 bar (0 ... +2.5 kPa)	All process fittings	Process fitting G½ (ISO 228-1)
One year	< 0.05 % x TD	< 0.1 % x TD	< 0.1 % x TD	< 0.25 % x TD
Five years	< 0.1 % x TD	< 0.2 % x TD	< 0.2 % x TD	< 0.5 % x TD
Ten years	< 0.2 % x TD	< 0.4 % x TD	< 0.4 % x TD	< 1 % x TD

Tab. 15: Determination of the long-term stability F_{stab} from the table, consideration for one year: $F_{stab} = 0.05 \% \times TD = 0.05 \% \times 8.2 = 0.41 \%$

4. Calculation of the total deviation

- 1. step: Basic deviation F_{perf}

$F_{perf} = \sqrt{((F_T)^2 + (F_{KI})^2)}$

$F_T = 0.69 \%$

$F_{KI} = 0.16 \%$ (calculation of above table)

$F_{perf} = \sqrt{(0.69 \%)^2 + (0.16 \%)^2}$

$F_{perf} = 0.71 \%$

- 2. step: Total deviation F_{total}

$F_{total} = F_{perf} + F_{stab}$

$$F_{\text{perf}} = 0.71 \% \text{ (result of step 1)}$$

$$F_{\text{stab}} = 0.41 \% \text{ (calculation of above table)}$$

$$F_{\text{total}} = 0.71 \% + 0.41 \% = 1.12 \%$$

The total deviation of each sensor is hence 1.12 %.

5. Calculation of the total deviation of the measuring system

Both sensors are included in the calculation of the total deviation of the measuring system. With 4 ... 20 mA master sensors the thermal error of the analogue output is also added:

$$F_{\text{total}} = \sqrt{(F_{\text{total-Master}})^2 + (F_{\text{total-Slave}})^2 + (F_a)^2}$$

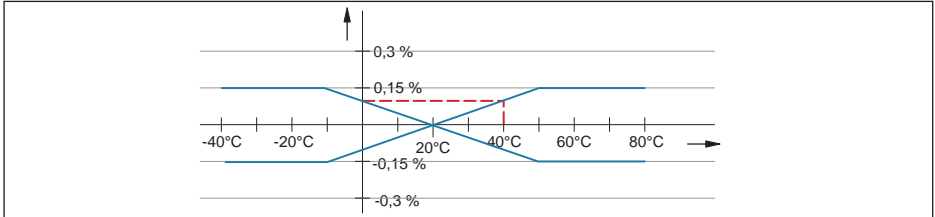

Fig. 36: F_a through thermal change current output, in this example = 0.1 %

$$F_{\text{total}} = \sqrt{(1.12 \%)^2 + (1.12 \%)^2 + (0.1 \%)^2} = 1.6 \%$$

The total deviation of the measuring system is hence 1.6 %.

Deviation in mm: 1.6 % of 500 mm = 7.9 mm

The example shows that the measurement error in practice can be considerably higher than the basic deviation. Reasons are temperature influence and Turn down.

The thermal change of the current output is in this example is negligible.

9.4 Dimensions

Housing

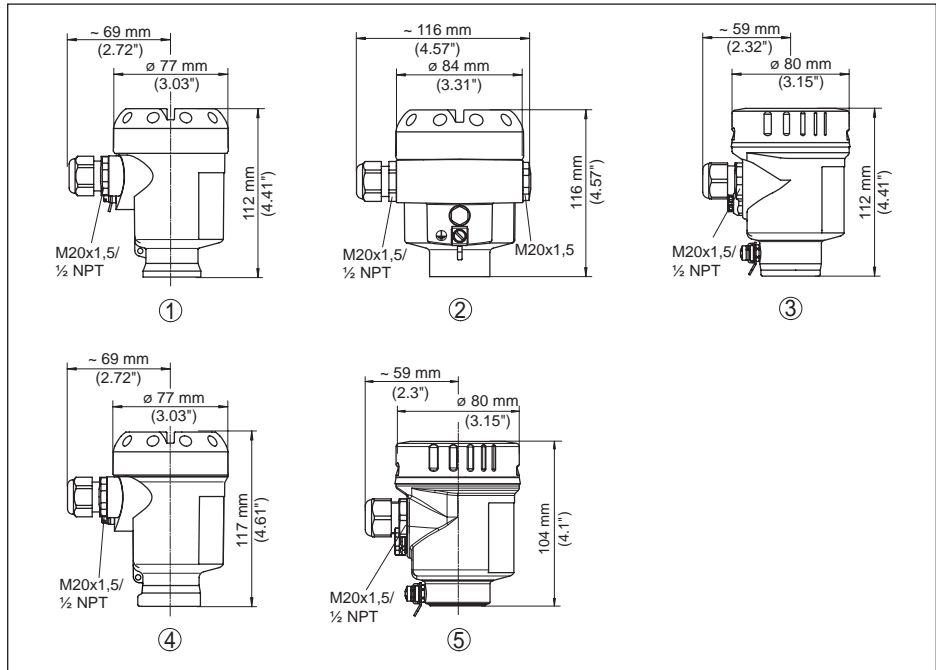

Fig. 37: Housing versions in protection IP66/IP67 and IP66/IP68 (0.2 bar)

- 1 Plastic single chamber (IP66/IP67)
- 2 Aluminium - single chamber
- 3 Stainless steel single chamber (electropolished)
- 4 Stainless steel single chamber (precision casting)
- 5 Stainless steel single chamber (electropolished) IP69K

External housing with IP68 (25 bar) version

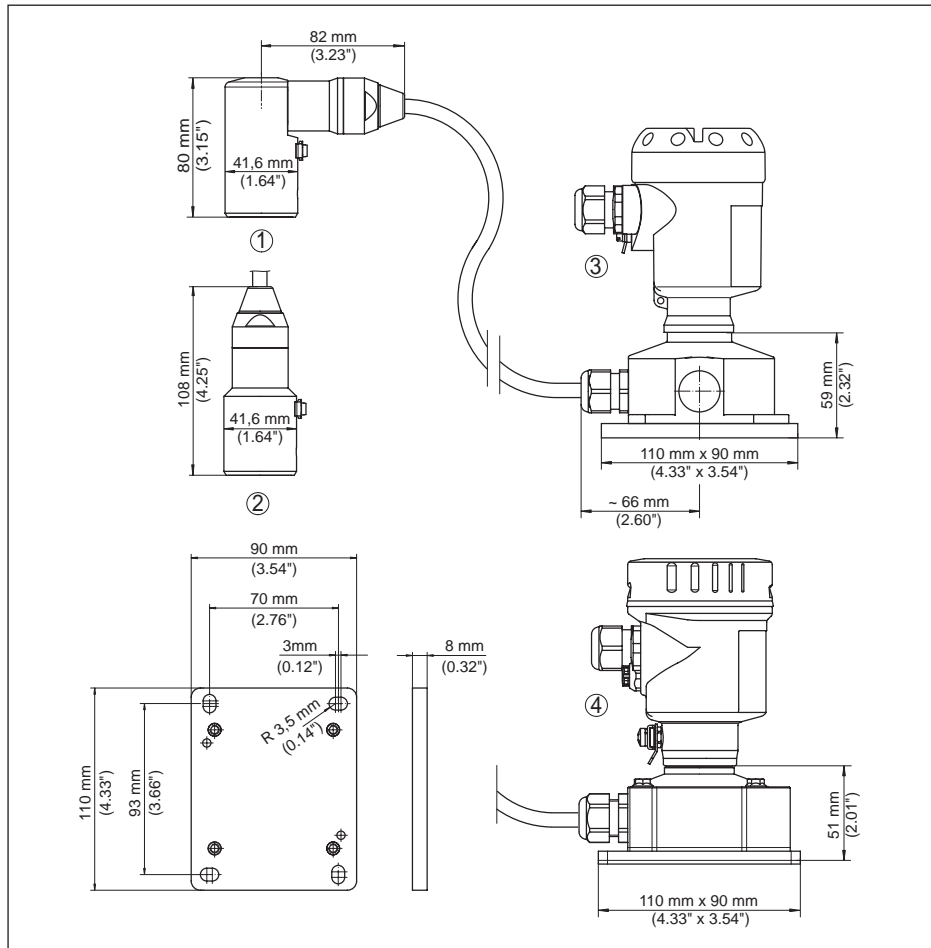

Fig. 38: IP68 version with external housing

- 1 Lateral cable outlet
- 2 Cable outlet axial
- 3 Plastic housing
- 4 Stainless steel housing, electropolished

CPT-2x, threaded fitting not front-flush

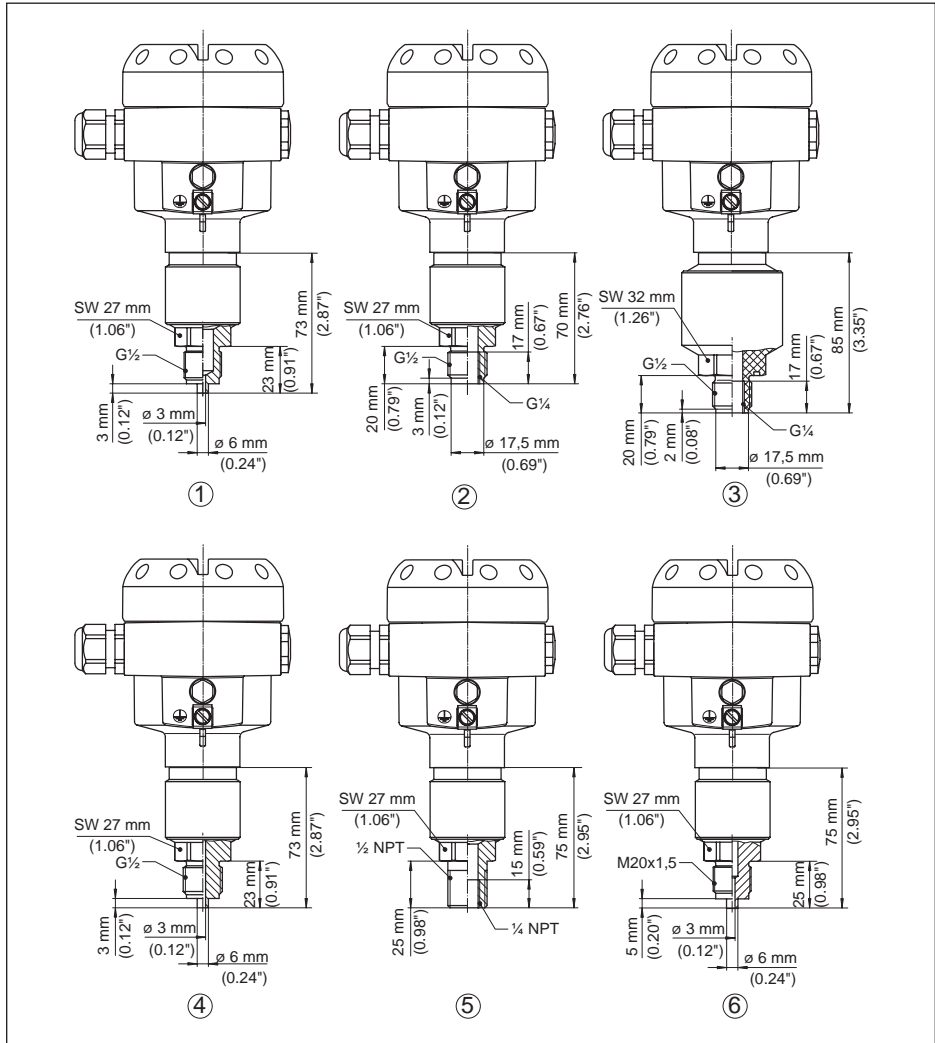

Fig. 39: CPT-2x, threaded fitting not front-flush

- 1 $G\frac{1}{2}$ manometer connection (EN 837)
- 2 $G\frac{1}{2}$ A inside $G\frac{1}{4}$ (ISO 228-1)
- 3 $G\frac{1}{2}$ A inside $G\frac{1}{4}$ A PVDF (ISO 228-1)
- 4 $G\frac{1}{2}$ manometer connection (EN 837) volume-reduced
- 5 $\frac{1}{2}$ NPT inside $\frac{1}{4}$ NPT
- 6 M20 x 1.5 manometer connection (EN 837)

CPT-2x, threaded fitting front-flush

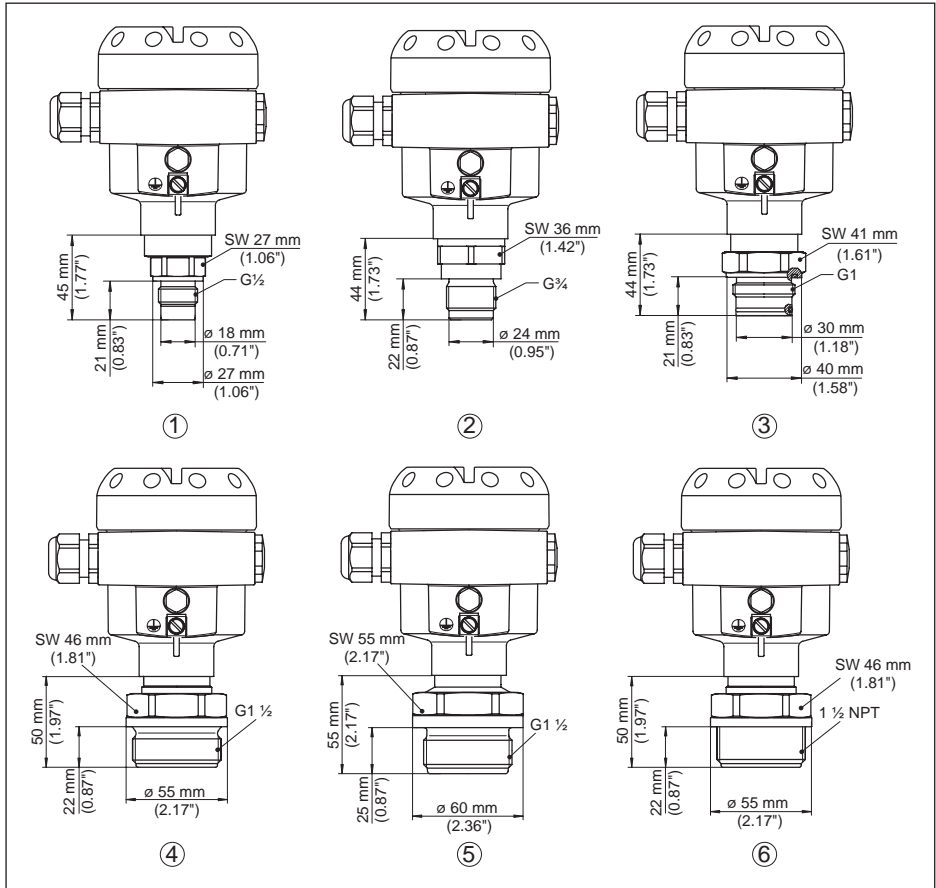

Fig. 40: CPT-2x, threaded fitting front-flush

- 1 $G\frac{1}{2}$ (ISO 228-1)
- 2 $G\frac{3}{4}$ (DIN 3852-E)
- 3 $G1$ A (ISO 228-1)
- 4 $G1\frac{1}{2}$ (DIN 3852-A)
- 5 $G1\frac{1}{2}$ A PVDF (DIN 3852-A-B)
- 6 $1\frac{1}{2}$ NPT (ASME B1.20.1)

For the version with temperature range up to 150 °C/302 °F, the measure of length increases by 28 mm (1.1 in).

For the version with "Second Line of Defense", the measure of length increases by 17 mm (0.67 in).

CPT-2x, hygienic fitting

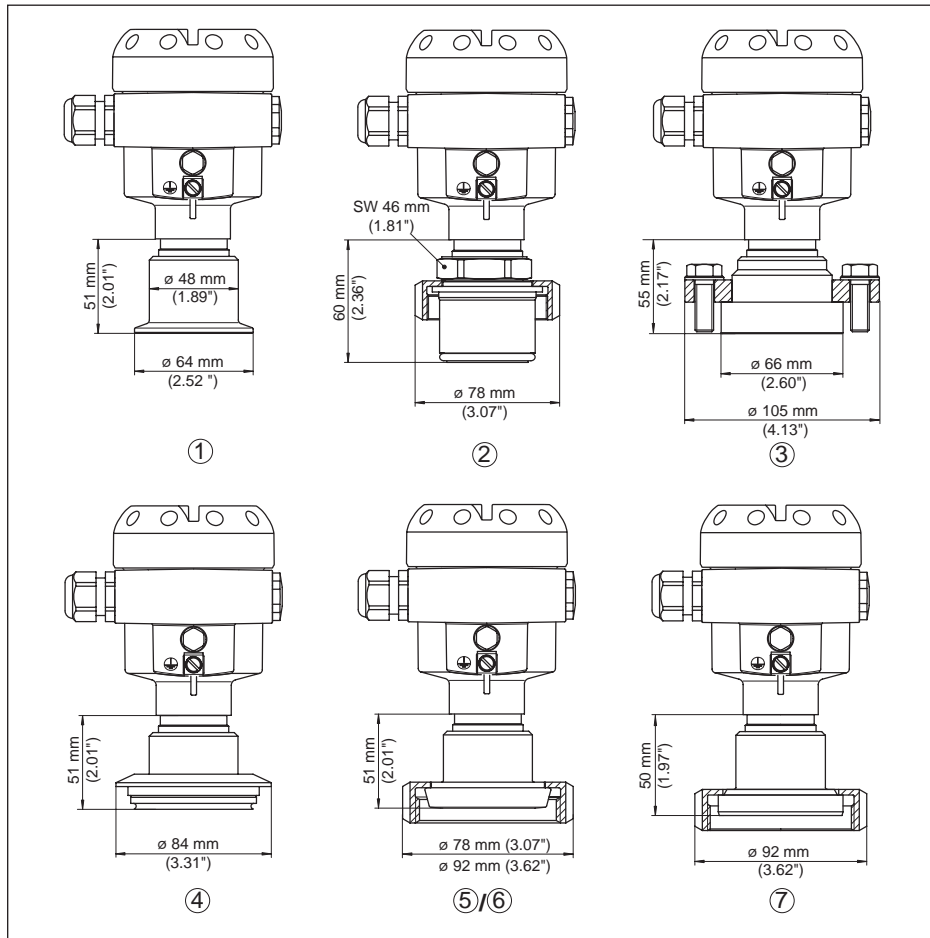

Fig. 41: CPT-2x, hygienic fitting

- 1 Clamp 2"
- 2 Hygienic connection with compression nut F40
- 3 DRD
- 4 Tuchenhagen Varivent DN 32
- 5 Slotted nut DN 40 according to DIN 11851
- 6 Slotted nut DN 50 according to DIN 11851
- 7 Slotted nut DN 50 according to DIN 11864-1

For the version with temperature range up to 150 °C/302 °F, the measure of length increases by 28 mm (1.1 in).

For the version with "Second Line of Defense", the measure of length increases by 17 mm (0.67 in).

CPT-2x, flange connection

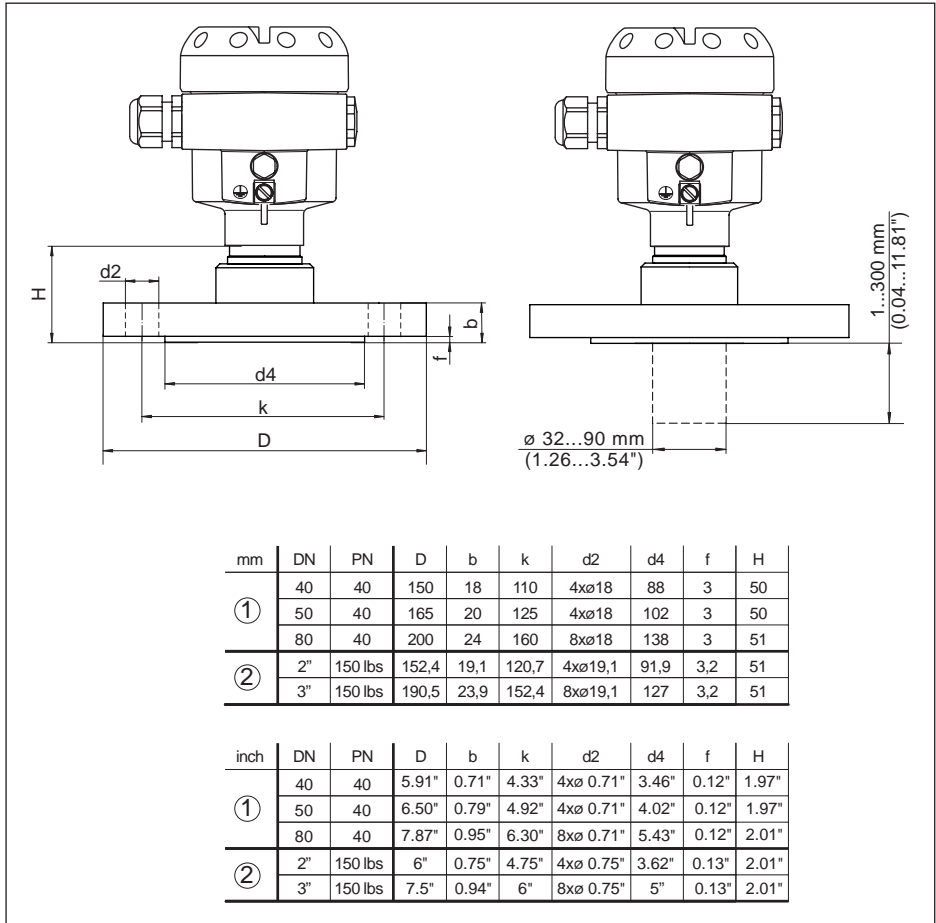

Fig. 42: CPT-2x, flange connection

1 Flange connection according to DIN 2501

2 Flange connection according to ASME B16.5

For the version with temperature range up to 150 °C/302 °F, the measure of length increases by 28 mm (1.1 in).

For the version with "Second Line of Defense", the measure of length increases by 17 mm (0.67 in).

CPT-2x, extension fitting

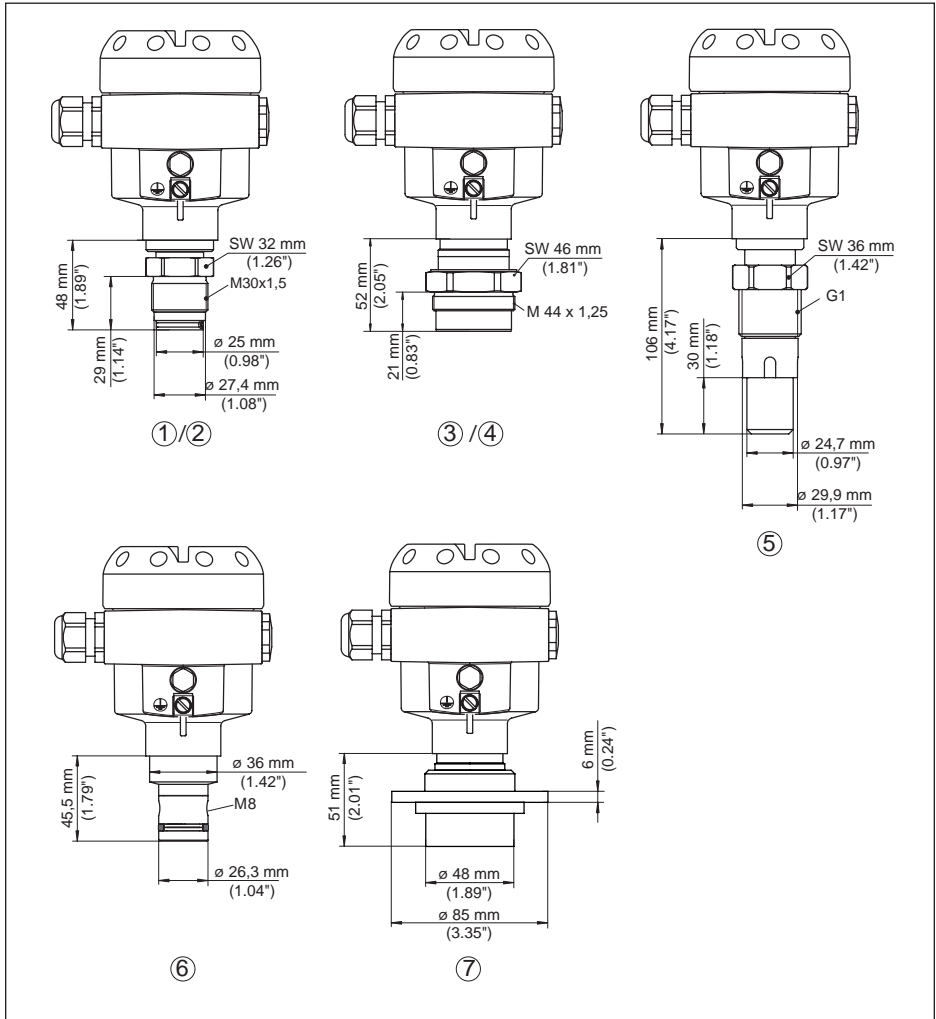

Fig. 43: CPT-2x, extension fitting

- 1 M30 x 1.5 DIN 13; completely front-flush
- 2 M30 x 1.5 DIN 13; for headbox
- 3 M44 x 1.25 DIN 13; pressure screw: Aluminium
- 4 M44 x 1.25 DIN 13; pressure screw: 316L
- 5 G1, ISO 228-1 suitable for PASVE
- 6 PMC 1" front-flush PN 6
- 7 DN 48 with tension flange

For the version with temperature range up to 150 °C/302 °F, the measure of length increases by 28 mm (1.1 in).

For the version with "Second Line of Defense", the measure of length increases by 17 mm (0.67 in).

CPT-2x, connection acc. to IEC 61518

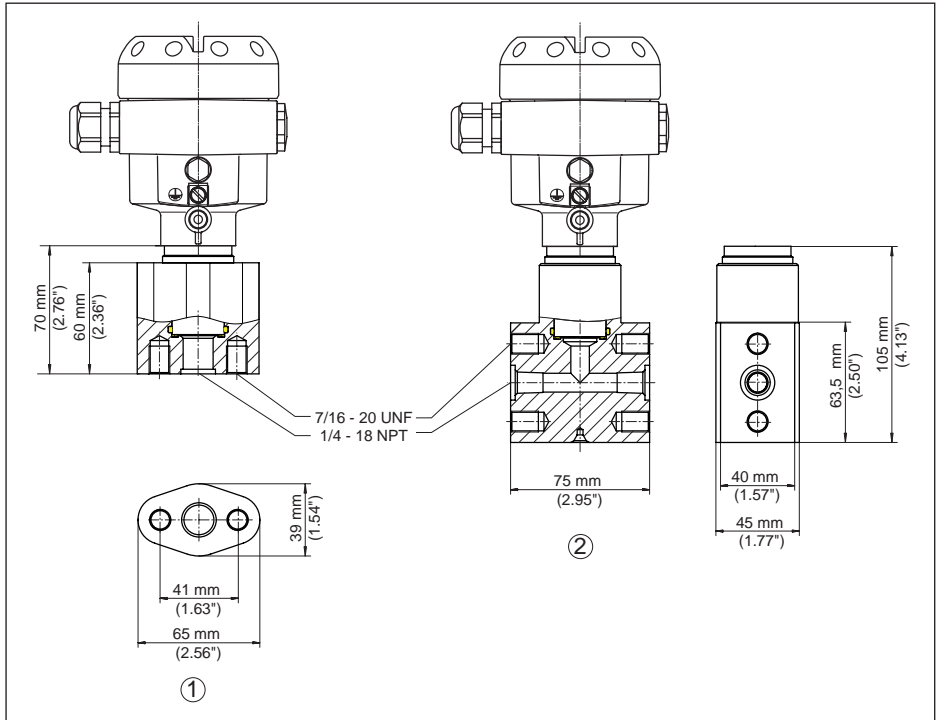

Fig. 44: CPT-2x, connection acc. to IEC 61518

- 1 Oval flange adapter
- 2 Top flange

For the version with temperature range up to 150 °C/302 °F, the measure of length increases by 28 mm (1.1 in).

For the version with "Second Line of Defense", the measure of length increases by 17 mm (0.67 in).

9.5 Trademark

All the brands as well as trade and company names used are property of their lawful proprietor/originator.

INDEX

A

- Adjustment 36, 37, 38, 39, 40
 - Level 41
 - Unit 34
- AI FB1 Function Block 42

C

- Channel 42
- Characteristic values of the differential pressure transmitter 45
- Connection
 - Steps 28
 - Technology 28
- Current output 45

E

- Electrical connection 27

F

- Fault
 - Rectification 47
- Fault rectification 47

G

- Gas-tight leadthrough (Second Line of Defense) 18

L

- Linearisation 42

M

- Maintenance 46
- Measurement setup
 - Density measurement 23
 - Differential pressure measurement 21
 - Interface measurement 22
 - Level measurement 20, 24

O

- Oxygen applications 17

P

- Parameterization example 35
- Peak value indicator 43
- Position correction 34
- Pressure compensation 19
 - Ex d 18
 - Second Line of Defense 18
 - Standard 18

S

- Seal concept 10
- Set display parameters 43
- Simulation 44

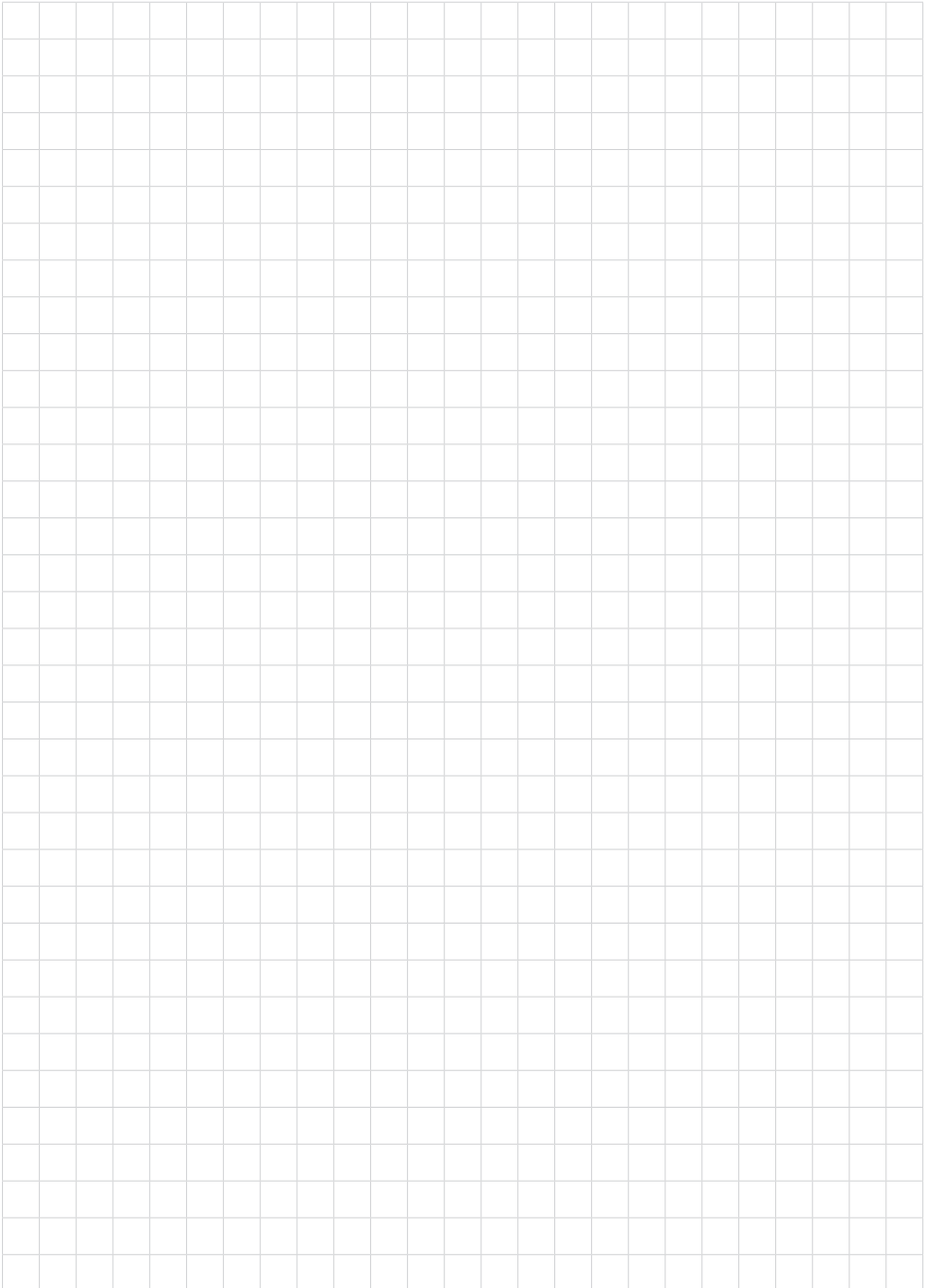

Printing date:

All statements concerning scope of delivery, application, practical use and operating conditions of the sensors and processing systems correspond to the information available at the time of printing.



WIKA Alexander Wiegand SE & Co. KG

Alexander-Wiegand-Straße 30

63911 Klingenberg

Germany

Phone (+49) 9372/132-0

Fax (+49) 9372 132-406

E-mail: info@wika.de

www.wika.de

55738-EN-200529